

SMARTER WHERE IT MATTERS

OFFERING FOR THE SHIPBUILDING INDUSTRY



OVER 50 YEARS OF EXPERIENCE

As mass-transport vehicles for trade and industry, ships are an essential part of the global economy. They move goods to customers around the world and keep businesses running. Your clients want vessels they can rely on. And when you put the pieces of ships together, you need tools you can rely on. Konecranes makes these tools.

For over 50 years, Konecranes has been a major global player in the design, delivery, and maintenance of shipyard lifting equipment. Around the world, from the largest to the smallest and everything in between, shipyards of all sizes are our customers. We are here to help build the safety and productivity of your operations both now and in the future.

This has been our mission for the last 50 years, and it will be our mission for the next 50 years and beyond.



Jussi Rautiainen
General Manager, Shipyard Cranes

www.konecranes.com

SMARTER WHERE IT MATTERS

A guide to the world's best
shipyard lifting equipment

Book facts

SMARTER WHERE IT MATTERS:
OFFERING FOR THE SHIPBUILDING INDUSTRY

Copyright © Konecranes 2012. All rights reserved.
“Konecranes”, “Lifting Businesses” and  are registered trademarks of Konecranes.

This publication is for general informational purposes only and we reserve the right to alter the product design and specifications. No statement of this publication shall be construed as a warranty or condition, express or implied, as to any product, its fitness for any particular purpose, merchantability, quality or representation of the terms of any sales agreement.

www.konecranes.com

CONTENTS

LIFTING YOUR BOTTOM LINE	6
SAFETY COMES FIRST AND LAST	8
SHIPYARD CRANE CONCEPTS	10
GO WITH THE FLOW	28
THE CRANES	42
SATISFIED CUSTOMERS	66

LIFTING YOUR BOTTOM LINE

Konecranes is a trusted brand proven by over five decades of shipyard experience, and customers that buy from us again and again. Our goal is not to sell you a cheap crane, but to minimize the total cost of ownership of the crane. Productivity is not only about the price of the crane; it is also about how the crane performs throughout its lifecycle. By making our cranes and services part of your production process, together we can maximize productivity and lift not only your loads, but your bottom line as well.

At the shipyard

Productivity is a yard-specific measure. Safety and reliability are a given, but the uniqueness of your production process guides the choice of solution. We are experts at finding solutions that fit your process perfectly.

Designing productivity

Our designs are based on unique solutions proven in practice. We know that your process is unique as well, but our experience with over one hundred shipyards around the world helps us to understand your needs. Oversizing or undersizing your lifting capacity will cause bottlenecks that harm productivity. Get us involved early, and we can provide not just cranes, but a complete lifting solution for your shipyard.

Delivering productivity

We hate waste. In a repeat-order business, our waste is your waste and vice versa. Not only do we tailor the crane itself for you, we also optimize the whole delivery based on your location and particular needs. Delivering productivity means that we keep our promises. Our long list of references, including many loyal customers who give us repeat business, shows that what we say is true.

Maintaining productivity

Our approach to maintenance is based on prevention rather than cure. Problems do not usually occur randomly, and they often show signs early if you know what to look for. Our skilled engineers have the experience to spot potential problems and fix them before they cause any trouble. You can relax, knowing that your cranes are working well and your business is fully productive.





SAFETY COMES FIRST AND LAST

The safety of your personnel operating the equipment and our personnel delivering it is always in our mind. Konecranes has great experience with safety in heavy industries like shipbuilding, offshore, nuclear, and steel. We understand that safety always comes first. Regardless of anything else, everybody should go home safe and sound when the yard gate closes.

Safety at shipyards

Shipyards are enormous in both size and load capacity, and present a range of potential safety hazards that must be addressed. For every customer, from the first conception of every new crane, through design, manufacture, delivery and maintenance, safety is built in all the way.

Designing safety

We always start with international safety standards, but rules and regulations are just the beginning. What's even more important is to understand your processes and minimize or eliminate risks which may arise due to extreme weather conditions, human error, component failure, maintenance and ergonomics. Our long experience in the shipbuilding industry gives us the expertise to reduce these risks. We know what works and what doesn't.

Delivering safety

We deliver safety with safe design. Every component and structural part of the crane follows our predefined and comprehensively documented quality plan. After installation, we inspect the equipment as a whole and test it thoroughly, simulating extreme operational conditions and human error. When we hand the crane over to your operators, we do so with complete confidence.

Maintaining safety

We want to take care of the crane across its working life, not just for the warranty period. As part of our standard delivery, we provide training and manuals for operating and maintaining the crane. The better the crane is maintained, the safer it is. We recommend a Konecranes service contract as an investment in the crane's continuing productivity and safety.



A photograph of a worker in a white hard hat and orange safety vest standing on a yellow metal walkway of a crane. The crane's main body is yellow and features the brand name 'KONECGRANES' in large, pink, sans-serif capital letters. Below the walkway, several thick black cables are suspended from metal brackets, forming a series of downward-curving arcs. The background is a clear, bright blue sky. In the bottom left corner, a portion of a yellow crane hook is visible, slightly out of focus.

KONECGRANES





SHIPYARD CRANE CONCEPTS

First, the product: Konecranes uses the latest technology combined with long industry experience to create market-leading lifting products for shipbuilding.

Second, the delivery: we know each shipyard is different. Every time we deliver a new crane, we assemble, install and commission it according to your specific needs. We then train your personnel to operate and take care of it.

Third, the service: with a Konecranes service package, our own specialist crew is ready and waiting to check and maintain your cranes whenever you need us. Your shipyard lifting equipment will keep working safely and efficiently for many years to come.

PRODUCT CONCEPT

Our cranes will work reliably in the weather conditions that prevail at your shipyard. We have delivered cranes to the Arctic north, where they withstand extreme sub-zero temperatures. We have also sent cranes to desert environments, where they endure dust storms and extreme heat. And everything in between.

They function well in every kind of climate and they come in all shapes and sizes. Konecranes shipyard lifting equipment ranges from small chain hoists that can raise a few dozen kilos, all the way up to the enormous **Goliath Gantry Crane**, which we have delivered with a lifting capacity of 2,000 tons combined with a 210-meter railspan in a single crane.

Safety and performance are quantitative measures that you know you can rely on from our proven track record. But in order to exceed your expectations, we also pay careful attention to several other factors that are very important:

Innovation for shipyards: working closely with shipyards, our own in-house research and development constantly refines our products with new technology and design innovations in a process of continuous improvement.

Rigidity: the tightest tolerances in structural flexibility enable accurate load handling.

Weight optimization: the weight of the crane is a key element in the design of infrastructure needed for crane installation. Our design makes intelligent use of light and rigid structures at a level that no other company in the industry can match.

Environmental features: many Konecranes products have a brake power feedback system as standard to cut energy costs and help preserve the environment.

Ease of maintenance: our general principle is that any component requiring maintenance shall be accessible, and all components that may fail during the life of the crane shall be easy to replace.

In-house technology: we design and manufacture the key components of our cranes in-house. This means that a high degree of component standardization can be achieved across your lifting equipment, making spare part supply simpler and maintenance more cost-effective.

Operator experience: Successful Formula One racing teams have a great car, a great driver and a great pit team – when all the parts work together flawlessly, the race is won. But it's the driver who stands on the podium. We like to think of your crane operators in the same way. Thanks to almost unlimited drive tuning options, comfortable cabin outfitting, high visibility, and fully adjustable seats, your operator is well taken care of.

Learn more about each specific product on pages 42–65









DELIVERY CONCEPT

After defining the right product concept for your needs, we develop and produce the delivery concept with you. Here, the most important question concerns the scope of delivery. In our terminology, we divide the scope into three levels:

- 1. Technology:** design, components, supervision and commissioning
- 2. Turnkey:** full design and delivery responsibility
- 3. Complete package:** turnkey and maintenance contract

The delivery concept is an optimization of cost, delivery time, and any limitations that your crane site may have. The quality of our delivery is a Konecranes standard that we adhere to in every case.

Design and components

Our own in-house parts are complemented with components from top brand suppliers. We will not accept any LCC components in our designs without extensive checks and pre-testing.

Manufacturing

The production of steel structures is sub-contracted under close Konecranes supervision. We use long-term partners who are as close as possible to your site to keep transport costs down.

Construction and installation

Based on your operational limitations, we will either ship the crane ready-assembled or ship the parts and erect the crane at your site. We always keep your current operations in mind and we always do our best to minimize interruptions caused by our work.

Commissioning

The next phase is start-up and testing. First, we tune and test the crane so we know it is safe, reliable, and operating according to its technical specifications. Then we ask your people to verify its operation in client witness tests.

After handover, our commissioning engineers will not leave your site until the crane is working to the satisfaction of your operators. A happy operator is a safe and efficient operator.

Once commissioning is done, we agree with you about how we should train and supervise your personnel as they start to use the crane.

Manufacturing the world's largest Goliath Gantry Crane

The product concept for the world's largest Goliath crane is entirely based on the needs of the customer that will use it: the Engevix-Ecovix shipyard in southern Brazil.





Pre-fitting the world's largest Goliath Gantry Crane

The finishing touches are being applied to the main girder sections of the world's largest Goliath crane, South Korea. Konecranes works with long-term manufacturing partners who are a fully integrated part of our delivery and quality control process.

The crane is too large to be shipped in one piece. We carefully pre-fit each block to its neighbor before shipping, ensuring that the weld joints fit properly. This speeds up the final fitting and welding work at the customer site.





Loading of main structures of the world's largest Goliath Gantry Crane

A section of the main girder of the world's largest Goliath crane being loaded onto a special heavy-lift vessel of the Jumbo Shipping Line. South Korea, June 2012. The customer is the Engevix-Ecovix shipyard in southern Brazil. When erected, commissioned and ready for work, this crane will have a lifting capacity of 2,000 tons and a rails span of 210 meters.

Transporting a crane of this size is a specialist engineering project in itself that affects the entire delivery, from the offering phase to erection at the customer site. We take into account the optimal block size for shipping, the shipping schedule and special factors such as bridges, low draught, tidal movements and rough winter conditions that might affect ship loading or unloading.

Nothing is overlooked. We do everything possible to ensure cost-effective, safe and on-time shipment.



Loading the trolley of the world's largest Goliath Gantry Crane in Hanko, Finland





Transporting the world's largest
Goliath Gantry Crane: en route
to Brazil







SERVICE CONCEPT

At Konecranes, we like to say that service is in our DNA.

Over 300,000 items of lifting equipment are under Konecranes maintenance contract – many are in use at shipyards worldwide. Every day, Konecranes service personnel work closely with their shipyard customers to provide the industry's Highest Lifecycle Value.

Prevention is better than cure

If you have your own maintenance crew, their understanding of the crane must be as comprehensive as possible. We train them to track and solve possible faults. To help your team, we have a comprehensive Crane Monitoring System (CMS) in our cranes to help find faults, fix problems, and identify possible future problems. You can do it yourself: the operator interface requires no special IT skills to run.

You decide how much you want us to be involved in crane maintenance. However, regardless of what service package you choose, we will always try to involve a local Konecranes service branch in the commissioning of your crane. We are the biggest crane service company in the world, because we believe that global service works best only when given local flavor.

Other services

In addition to inspection services, and maintenance programs, we can provide the following:

- Modernizations
- Repairs and improvements
- Moves and relocations
- Spare parts

We are able to provide these services for many makes and models of shipyard lifting equipment and many brands.

Learn more on page 62





CONCEPTS YOU CAN TRUST

With hardy, reliable cranes that can withstand extreme environmental conditions, advanced design using the latest in lifting technology, highly efficient manufacturing, installation, and operator training, and preventive maintenance by our very competent service engineers, you know that we are expert at what we do: designing, building, and servicing cranes.

Our shipbuilding cranes have been expressly designed for the purpose of building ships. And we work closely with you in the design phase to ensure that each crane that you buy is specially tailored for your own shipyard. So you know that you have exactly the right equipment for the job that you have to do.







GO WITH THE FLOW

An efficient shipyard maintains a continuous flow of activity from the moment the raw material arrives to the launch of a completed ship. Every step must be handled correctly to keep to the demanding schedules that modern customers require. Reliable, long-lasting cranes and lifting equipment from Konecranes will help you keep your manufacturing and assembly processes moving with a minimum of downtime and a maximum of value.

LIFTING THE SHIPBUILDING PROCESS

A shipyard is a unique production ecosystem bringing raw material suppliers with their own value-adding activities into a constant flow of steel, assembly and outfitting. There are no independent streams in this flow: all the channels come together and leave the yard as a completed ship. The only real dam is the dry dock gate.

Most shipbuilding material arrives by ship or barge. The first crane to handle it is a **ship unloader**. The warehousing area stores and moves the material with small **gantries** and sometimes **plate handling cranes**. From pre-treatment, it continues into the workshop.

Light overhead cranes bring steel plates into the cutting area. As the welding of plates creates bigger segments that then become ship blocks, each crane gets bigger accordingly. As the cranes increase in size, they need more features and special attachments to handle their loads.

When the ship blocks are ready to be moved outside, it's time for the **Goliath Gantry Crane** to take over. The bigger the blocks you can lift and assemble, the less valuable dry dock time will be consumed by the hull in progress. **Jib cranes** on the sides can work at the same time to outfit the ship.

As soon as the hull is ready for launch, the dry dock gate is opened. The outfitting quay with jib cranes or **floating dock cranes** will continue the work from where the dry dock jibs finished.

Whatever you need to lift and flow, we have a safe and efficient solution. The following pages will show you the solutions we provide for every phase of your shipbuilding process.









PLATE HANDLING PROCESS

The steel plates arriving by sea are welcomed by a plate unloading crane that can reach all the way from the dock to the far side of the ship. Time is of the essence: fast unloading means that the ship can leave as soon as possible.

You can maximize unloading efficiency when your unloading crane fits the size of the ships and barges that supply your shipyard. Unloading is then a continuous movement, without unnecessary side moves or sway, so set-up and set-off times are much shorter for each duty cycle. Because the size and shape of incoming material varies, you need a stable slewing trolley and quick-change unloading attachments. Of course, the individual cycle time counts only if the whole unloading process can be run without technical hiccups or safety hazards.

Plate storage varies according to how you organize your storage area and the level of automation. Be that as it may, you need to find, pick up and move materials as needed. In this part of the process, your cranes must fit each storage cell. Time might not be as critical as when unloading, but lack of reliability is a major cost factor if your cranes cannot be used to their full potential. The level of automation can be adjusted according to the needs of your shipyard.

The Konecranes plate handling gantry family covers the full range of load capacities and site conditions. Our plate unloaders are tailored to your shipyard for maximum efficiency and safety. Using the latest technology, we can provide a completely automated warehouse solution that makes moving your shipbuilding material simple, safe, and easy.

Learn more on page 48

KONECRANES®

100 t





BLOCK MANUFACTURING PROCESS

After you have cut the steel, you start welding. As you join pieces together, the size and weight of the loads increase and the lifting capacity of your workshop cranes must also increase. Your block manufacturing process defines how large the blocks can be. Your cranes must be able to lift and carry the blocks – they shouldn't set the limits.

Depending on your workshop building and support structures, the cranes can be of **bridge, semi-gantry or gantry design**. Fitting and welding are time-intensive, but lifting and moving should not be. The most important factors for crane efficiency are reliability, accuracy, and the degree of process fit.

Good process fit means that your cranes are correctly sized and equipped with special features that help the process below the hooks. For example, they can slew or rotate the load. As the blocks take shape, load handling becomes more critical and challenging. Visibility is not always clear from every side, so the control station should be flexible.

You probably also want to use miscellaneous support equipment like **chain blocks** that finely adjust fitting, or **fork lift trucks** that transport smaller parts to and from the workshop quickly.

When the workshop is working at full capacity, with every crane in operation, it's good to be able to monitor crane use from a remote monitoring computer station.

You can improve your process by improving material handling across every phase. Whatever your needs, we can offer you a solution that has already proven its reliability in a real workshop setting. Our experience is your advantage, whether you are designing a new shipyard or modernizing an existing one.

Learn more on page 50 and 60





HULL ASSEMBLY PROCESS

The most valuable time at your shipyard is the time your work-in-progress stays in dry dock. One of the most important variables in the total productivity of your shipyard is the size and completeness of the blocks that go to make the hull. When a very big block needs lifting, it's time for the Goliath Gantry Crane to take over.

The Goliath Gantry Crane is designed to travel over the whole dry dock. Block welding and outfitting areas will often be located beside it. A Goliath can lift a load of over 2,500 tons up to 90 meters high. Meanwhile, you can drive the gantry and travel the trolleys. There is no compromise on safety. The control system has built-in failsafes that help to prevent operator error. The same system provides high-precision load control for accurate positioning of the hull blocks during fitting.

Only after the crane is known to be completely safe under all conditions can productivity be considered. Our Goliath crane engineers pay careful attention to rigidity, hook set-up flexibility, tandem lift, and wheel load. We take great care with these issues to save time and expense dealing with positioning, rigging, and any additional construction needed to accommodate such a massive crane.

In the last 40 years, Konecranes has supplied over 60 Goliath Gantry Cranes to shipyards around the world, including some of the world's biggest. They buy from us because they know we have the industry knowledge and experience to deliver exactly what they need. We have delivered unique single-girder Goliath cranes that perfectly fit wide-span requirements. We also make double-girder Goliath cranes for smaller spans. Our Goliath Gantry Crane is the landmark of your shipyard and an industry benchmark.

Learn more on page 52





HULL OUTFITTING PROCESS

The hull is still under intensive outfitting after launch. Smaller equipment is lifted and installed onboard or lowered through the hatches. These loads are relatively light and speed is of the essence. It's time for the outfitting cranes to take over. You probably outfit the hull with portal jib cranes.

Your crane operators will be more productive if their cranes are reliable and accurate. High speed requires smooth cooperation between operator and equipment. Any unwanted movement sways the load in at least two dimensions, causing possible safety hazards. There is no one-type-fits-all solution, even in outfitting. The main types of cranes used here are single boom, double boom and hammerhead.

Double boom construction is the most rigid and accurate in load handling. It is also the simplest to stow, so it is easier to work with neighboring cranes.

A single boom crane is more economical than a double boom, and with the latest design advances, it can also be made rigid for heavier loads. Floating dock cranes are a special type of single boom crane for floating dock launches and repairs.

Hammerhead cranes are usually the cheapest option, but are not often used, because the boom is always set at maximum outreach, and so it is difficult to manage safety easily. Space is always an issue in a busy shipyard environment.

Konecranes provides a comprehensive range of outfitting cranes with full tailoring for your shipyard and your lifting needs. In the last 50 years, we have supplied more than 450 portal jib cranes to customers around the world. Today's cranes use the latest technology combined with time-proven engineering for the most efficient outfitting cranes on the market today.

Learn more on pages 46 and 54–59

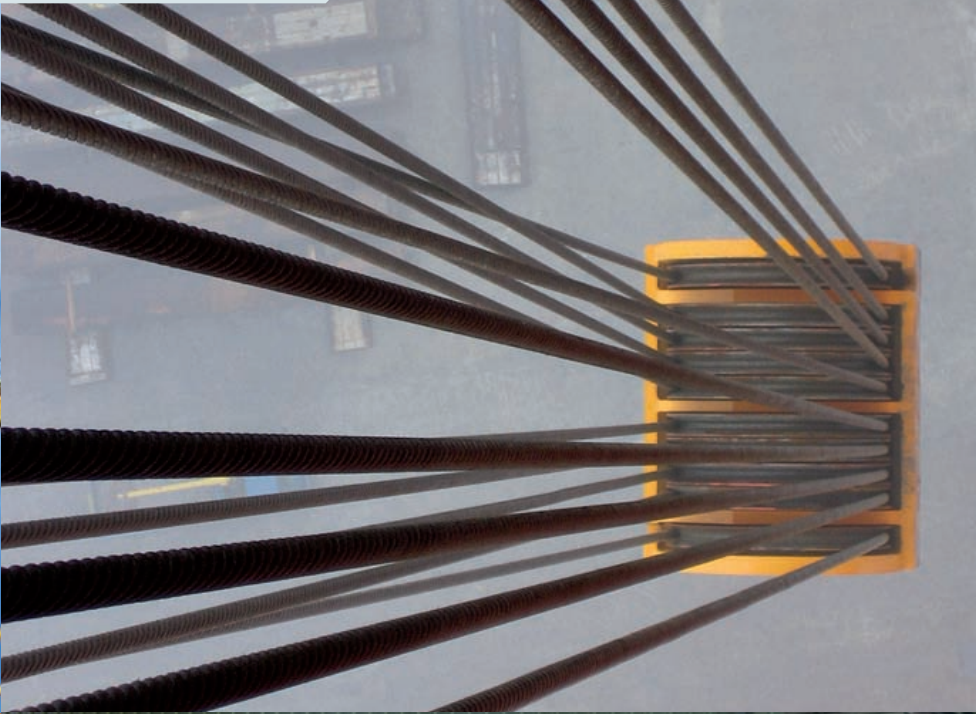



WE KNOW SHIPBUILDING

You can be sure that Konecranes knows cranes. But we also know about shipyards. Our deep knowledge of shipbuilding processes helps us to deliver cranes that are specially designed for your industry. They are made to handle plates, lift ship blocks, and outfit the hull.

For over 50 years, shipbuilders have been coming to Konecranes for our lifting equipment to help them in their businesses. They trust us because our proven track record in the industry shows that we know what a shipyard needs.







THE CRANES

Choosing the right equipment for your shipyard is a result of understanding the yard's operational needs today and how those needs are likely to evolve tomorrow. As your operation grows, we work closely with you to satisfy your expanding needs. Konecranes makes cranes and lifting equipment for every stage of the shipbuilding process. From moving the raw steel into your plate workshop, building the plates into hull blocks, joining the blocks together to make a hull, and outfitting the finished structure – you will find the right equipment for every task, and we will tailor it for your particular shipyard.

SMARTER FROM EVERY PERSPECTIVE

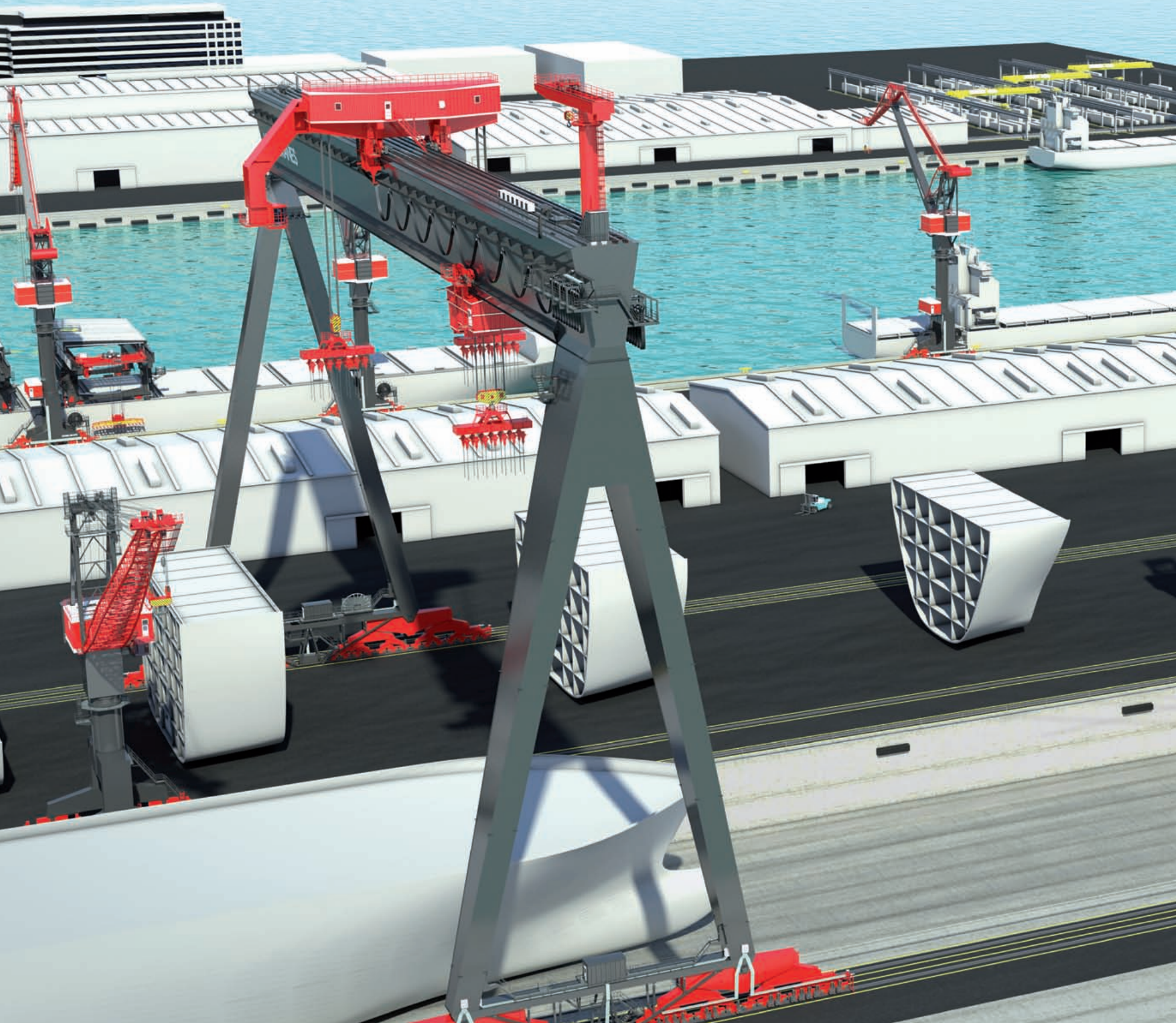

OPERATIONS

Reliability and performance

- Key components made in-house
- Other components from industry-leading suppliers
- Intelligent structure gives excellent stability
- Unique rope arrangement for minimal sway and safe slewing

MAINTENANCE

Easier maintenance

- Intelligent Crane Monitoring System (CMS) supports fault tracking
- Less hydraulics
- Direct access to maintenance points
- Service modularity

OPERATOR

Safe and ergonomic

- All-in-one controls
- High visibility in multiple directions
- Comprehensive and adjustable information panels
- Safe and easy crane access

FINANCES

Lowest lifecycle cost

- Dedication to long-term partnership
- Based on Total Cost of Ownership approach
- Low energy consumption
- High productivity with short cycle times

COMMUNITY

Eco-efficient

- Less hydraulics
- Optimized equipment weight
- Energy-saving Konecranes drives
- Power feedback recycling to minimize energy consumption

OPERATIONS MANAGER

Best performance

- Quick vessel turnaround
- Priority on safety
- Reduced emissions
- Support close to you

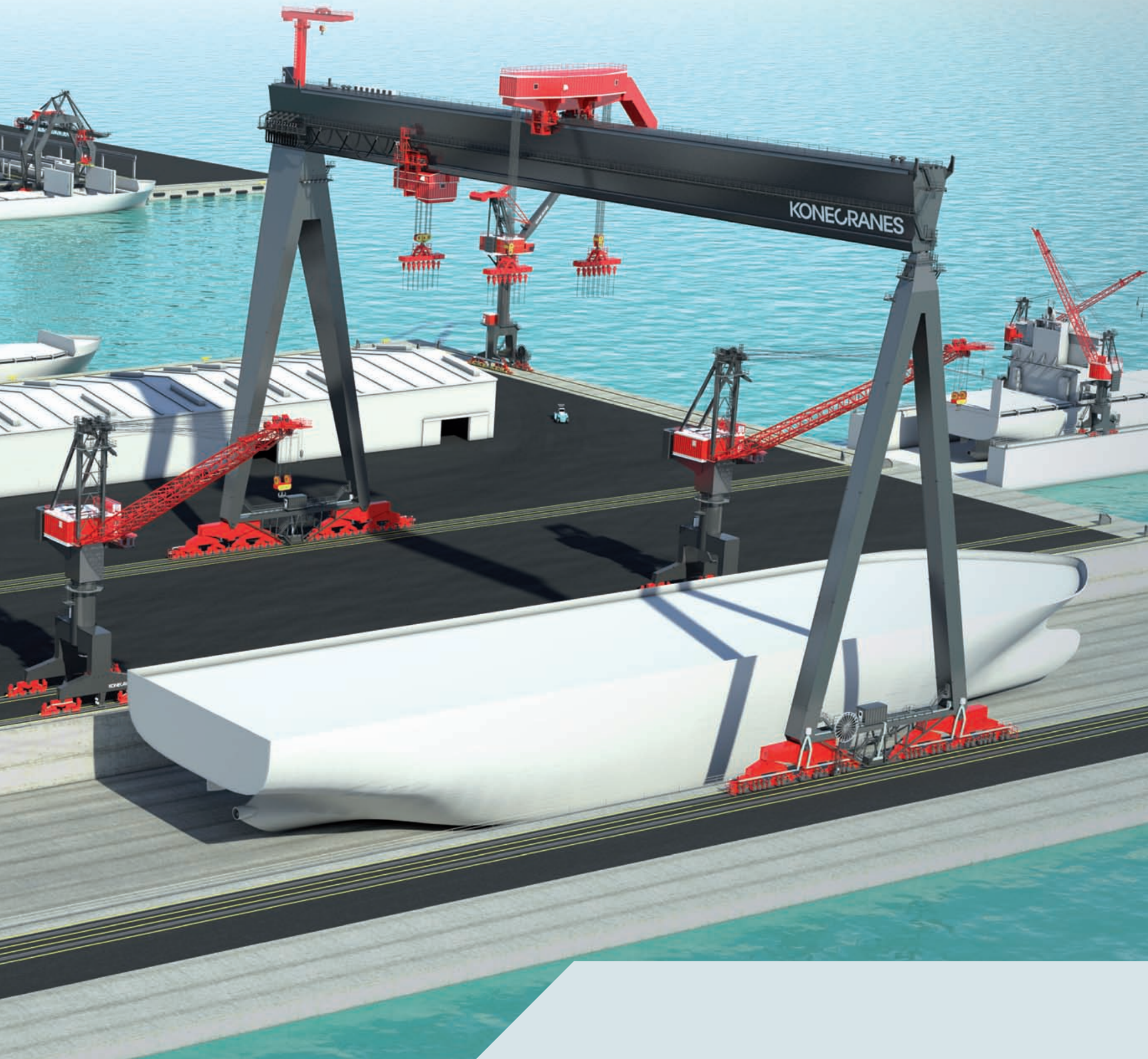
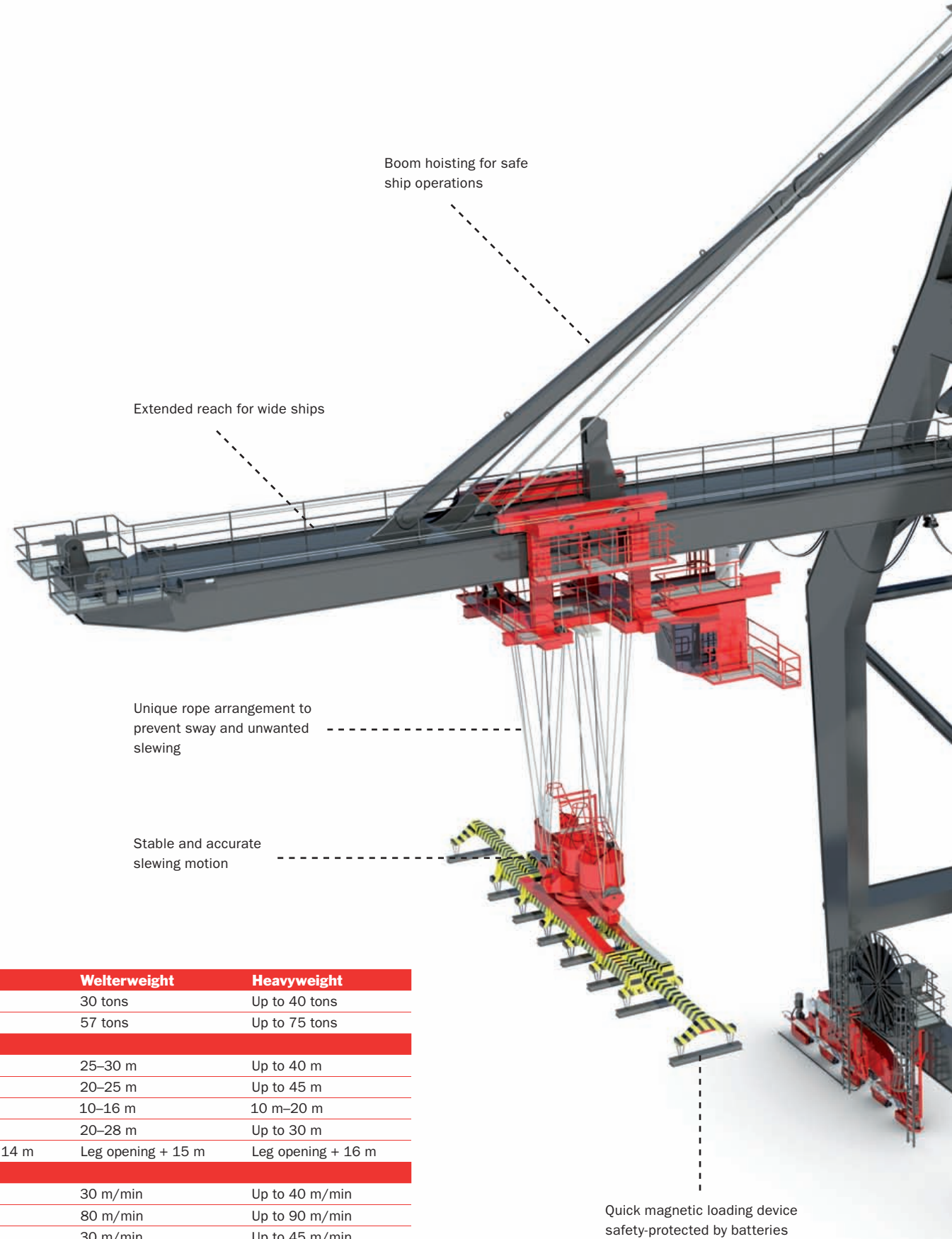
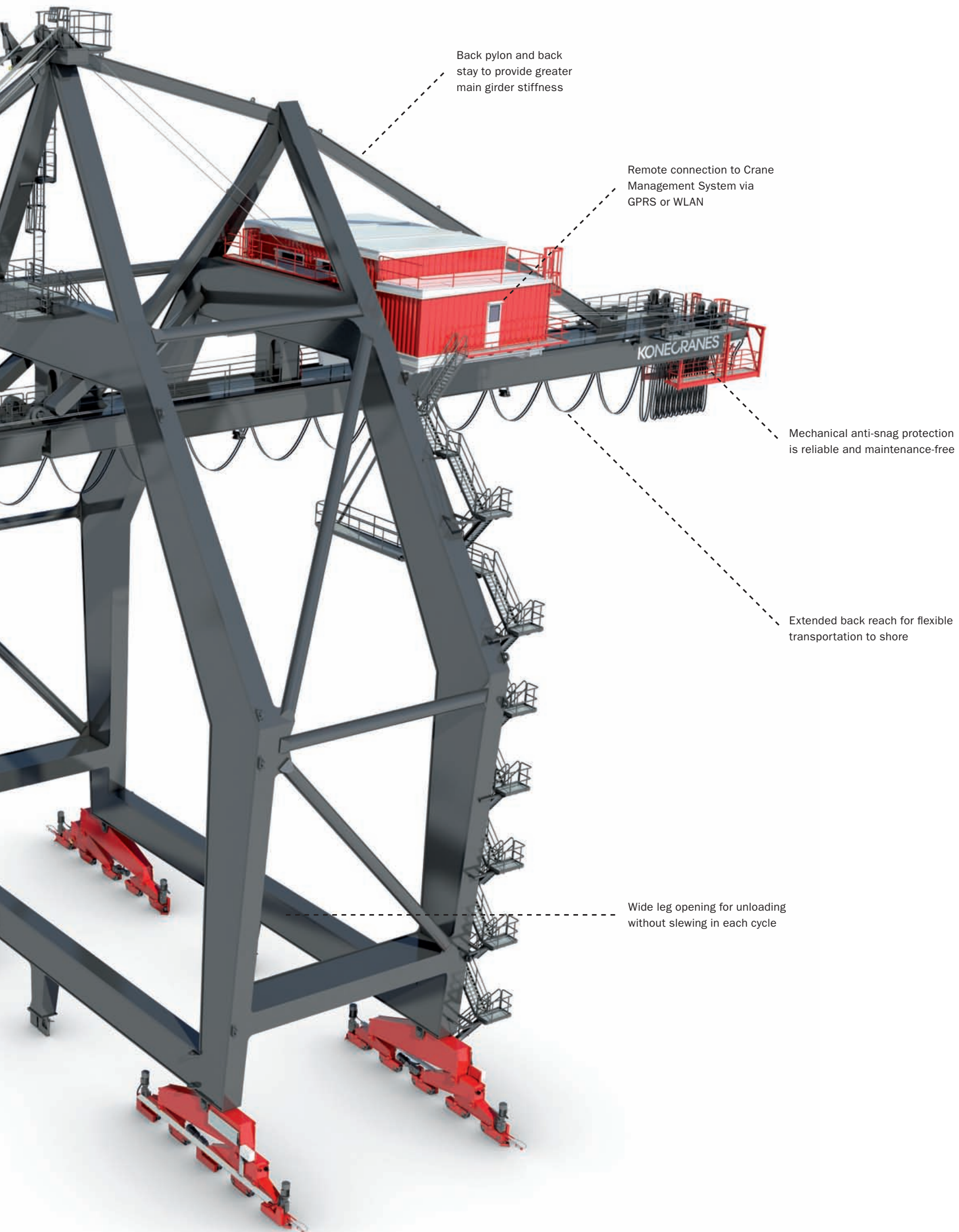

PLATE UNLOADING CRANE



Lifting capacity	Flyweight	Welterweight	Heavyweight
Under magnets	20 tons	30 tons	Up to 40 tons
Total	40 tons	57 tons	Up to 75 tons
Main dimensions			
Outreach	20–25 m	25–30 m	Up to 40 m
Lifting height	14–19 m	20–25 m	Up to 45 m
Rail span	10–16 m	10–16 m	10 m–20 m
Leg opening	20–28 m	20–28 m	Up to 30 m
Buffer to buffer	Leg opening + 14 m	Leg opening + 15 m	Leg opening + 16 m
Speeds			
Gantry travel speed	30 m/min	30 m/min	Up to 40 m/min
Trolley traversing speed	70 m/min	80 m/min	Up to 90 m/min
Hoisting speed, full load	25 m/min	30 m/min	Up to 45 m/min
Hoisting speed, no load	35 m/min	50 m/min	Up to 70 m/min
Slewing	0.5 m/min	0.5 rpm	Up to 0.5 rpm
Electrical systems			
Crane power supply	Cable reel	Cable reel	Cable reel
Trolley power feed	Festoon	Festoon	Festoon
Drive and control system	Konecranes AC	Konecranes AC	Konecranes AC
Maintenance			
Crane Monitoring System	Standard	Standard	Standard
Remote diagnostics	Option	Option	Option



Back pylon and back stay to provide greater main girder stiffness

Remote connection to Crane Management System via GPRS or WLAN

Mechanical anti-slag protection is reliable and maintenance-free

Extended back reach for flexible transportation to shore

Wide leg opening for unloading without slewing in each cycle

PLATE HANDLING CRANE

This crane can be equipped with a high-visibility cabin or radio remote control.

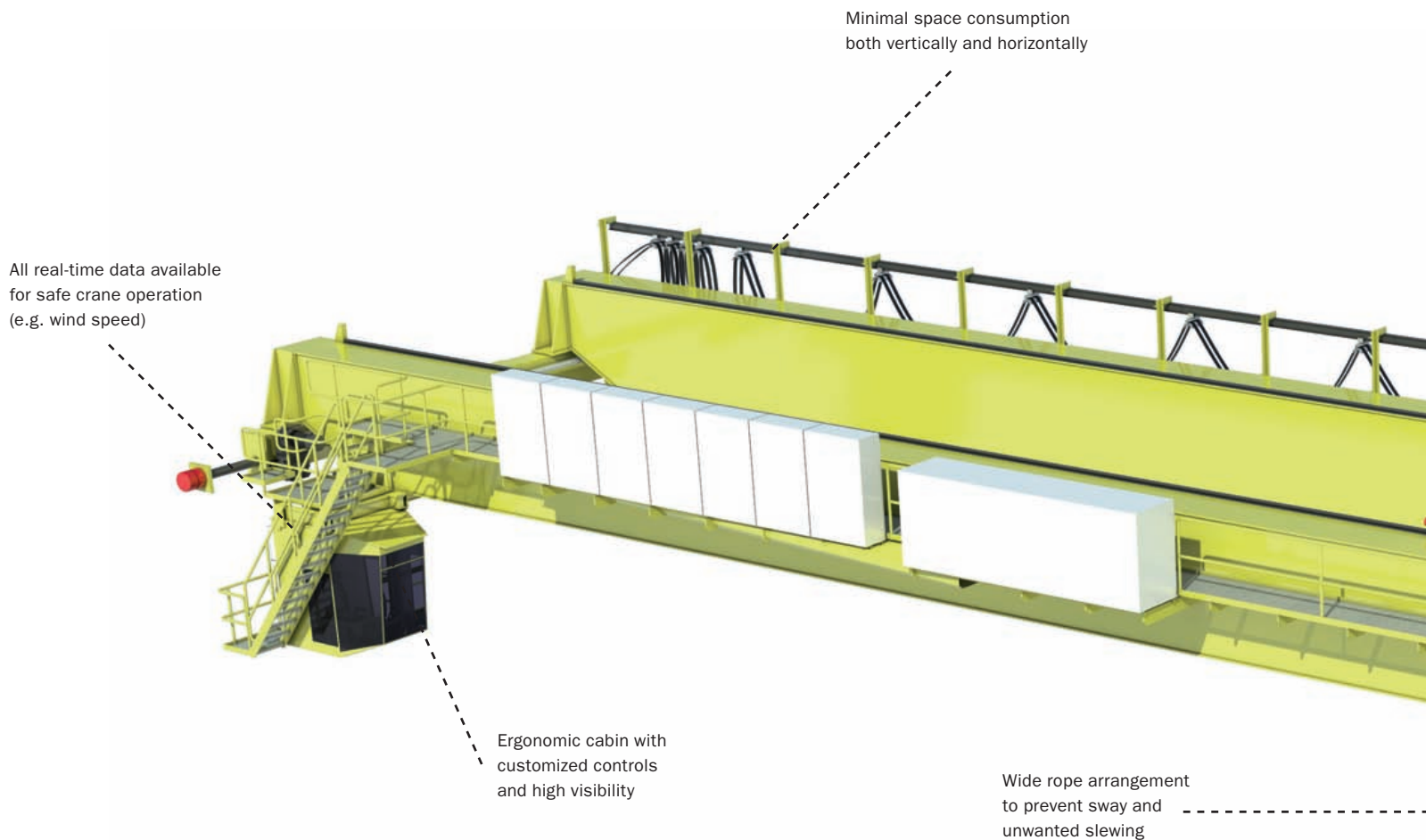

Lifting capacity	CXT100-CXT600	SM17-SM18	LV10-LV30
Maximum capacity	1–16 tons	25–80 tons	10–30 tons (under magnet)
Auxiliary hoist			CXT
Main dimensions			
Span	Up to 40 m	Up to 45 m	Up to 50 m
Lifting height	Up to 20 m	Up to 20 m	Up to 15 m
Buffer to buffer	Down to 4 m	Down to 6 m	Down to 8 m
Speeds			
Bridge travel speed	30–50 m/min	30–50 m/min	40–100 m/min
Trolley traversing speed	15–25 m/min	20–40 m/min	20–50 m/min
Slewing speed			0.50 r/min
Hoisting speed with nominal load	4–10 m/min	4–10 m/min	5–12 m/min
Electrical systems			
Bridge power supply	Conductor	Conductor	Conductor
Trolley power supply	Festoon	Festoon	Festoon
Drive and control system	Konecranes AC	Konecranes AC	Konecranes AC
Control	Radio	Radio	Radio/Cabin
Maintenance			
Crane diagnostics	Standard	Standard	Standard
Remote diagnostics	Option	Option	Option

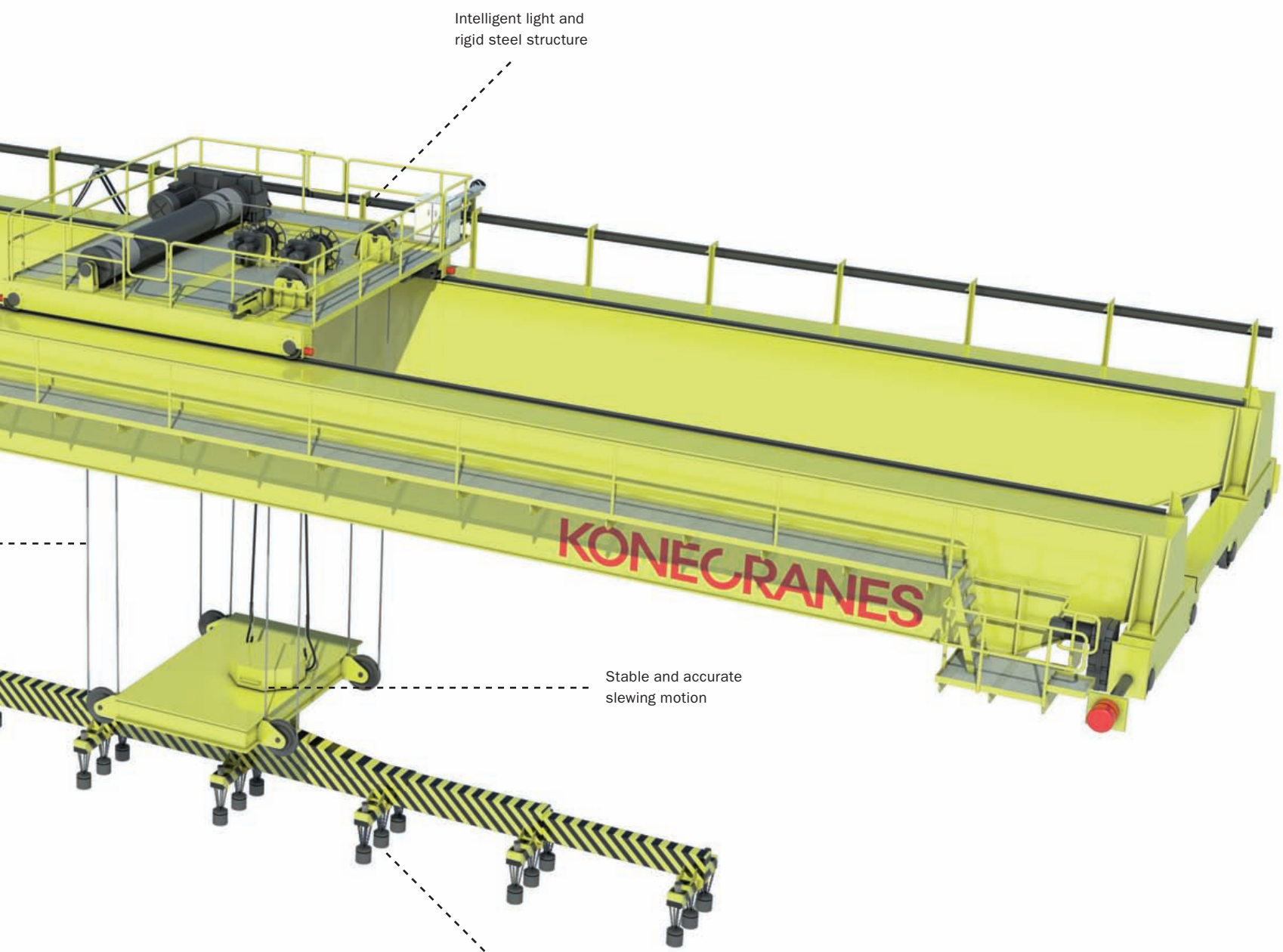

Intelligent light and rigid steel structure

Stable and accurate slewing motion

Quick magnetic loading device safety-protected by batteries

BLOCK HANDLING CRANE

This crane can be equipped with a high-visibility cabin or radio remote control.

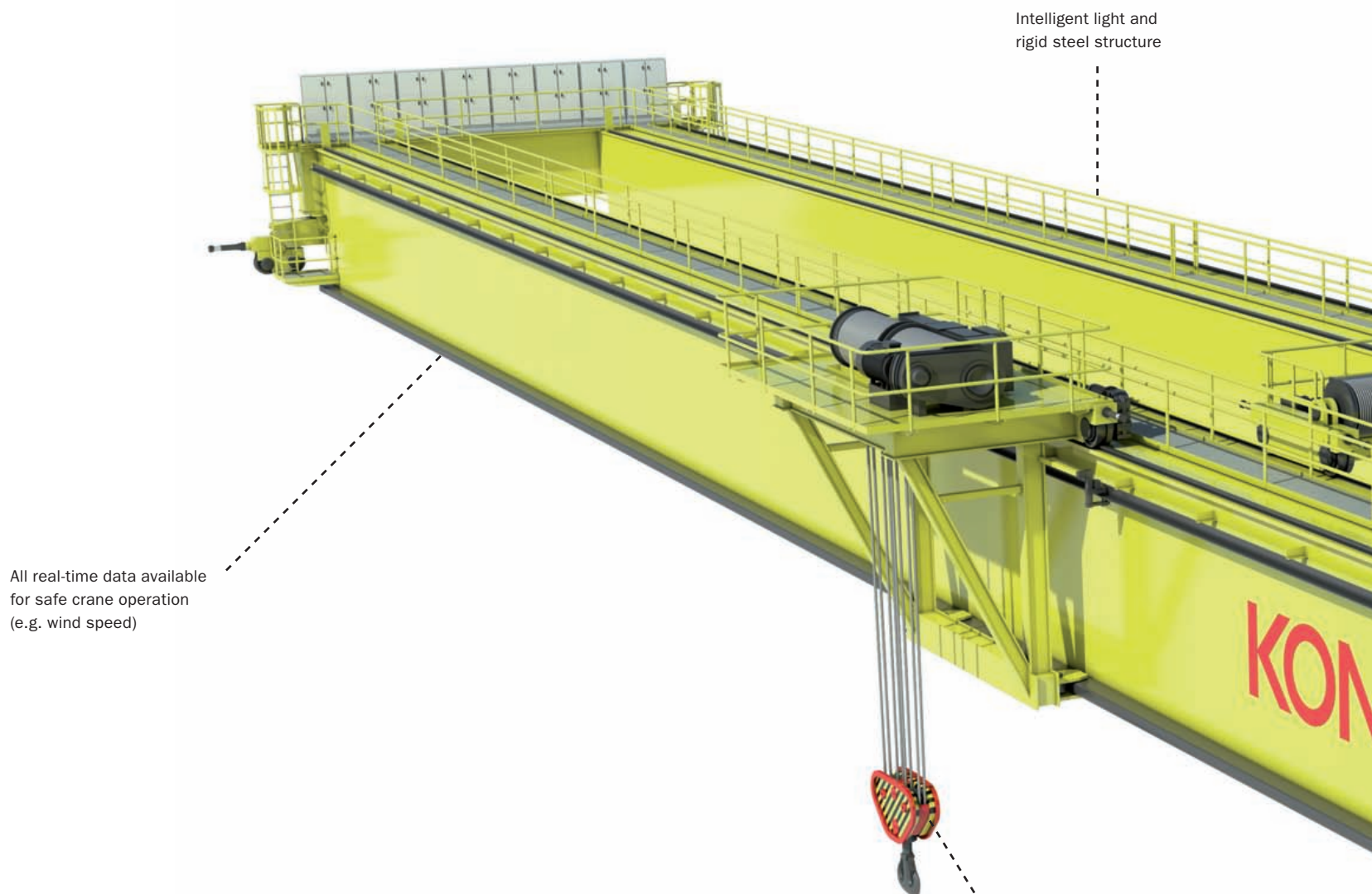

All real-time data available for safe crane operation (e.g. wind speed)

Intelligent light and rigid steel structure

Stable and accurate block rotation

Lifting capacity	CXT100-CXT600	SMT17-SMT20	LV50-LV350
Maximum capacity	1–16 tons	16–250 tons	50–350 tons
Auxiliary hoist		CXT	CXT
Main dimensions			
Span	Up to 110 m	Up to 60 m	Up to 80 m
Lifting height	Up to 20 m	Up to 30 m	Up to 40 m
Speeds			
Bridge travel speed	30–50 m/min	30–60 m/min	30–50 m/min
Trolley traversing speed	15–25 m/min	20–40 m/min	15–30 m/min
Hoisting speed with nominal load	4–10 m/min	3–10 m/min	3–10 m/min
Electrical systems			
Bridge power supply	Conductor	Conductor	Conductor
Trolley power supply	Festoon	Festoon	Festoon
Drive and control system	Konecranes AC	Konecranes AC	Konecranes AC
Control	Radio	Radio	Radio/Cabin
Maintenance			
Crane diagnostics	Standard	Standard	Standard
Remote diagnostics	Option	Option	Option

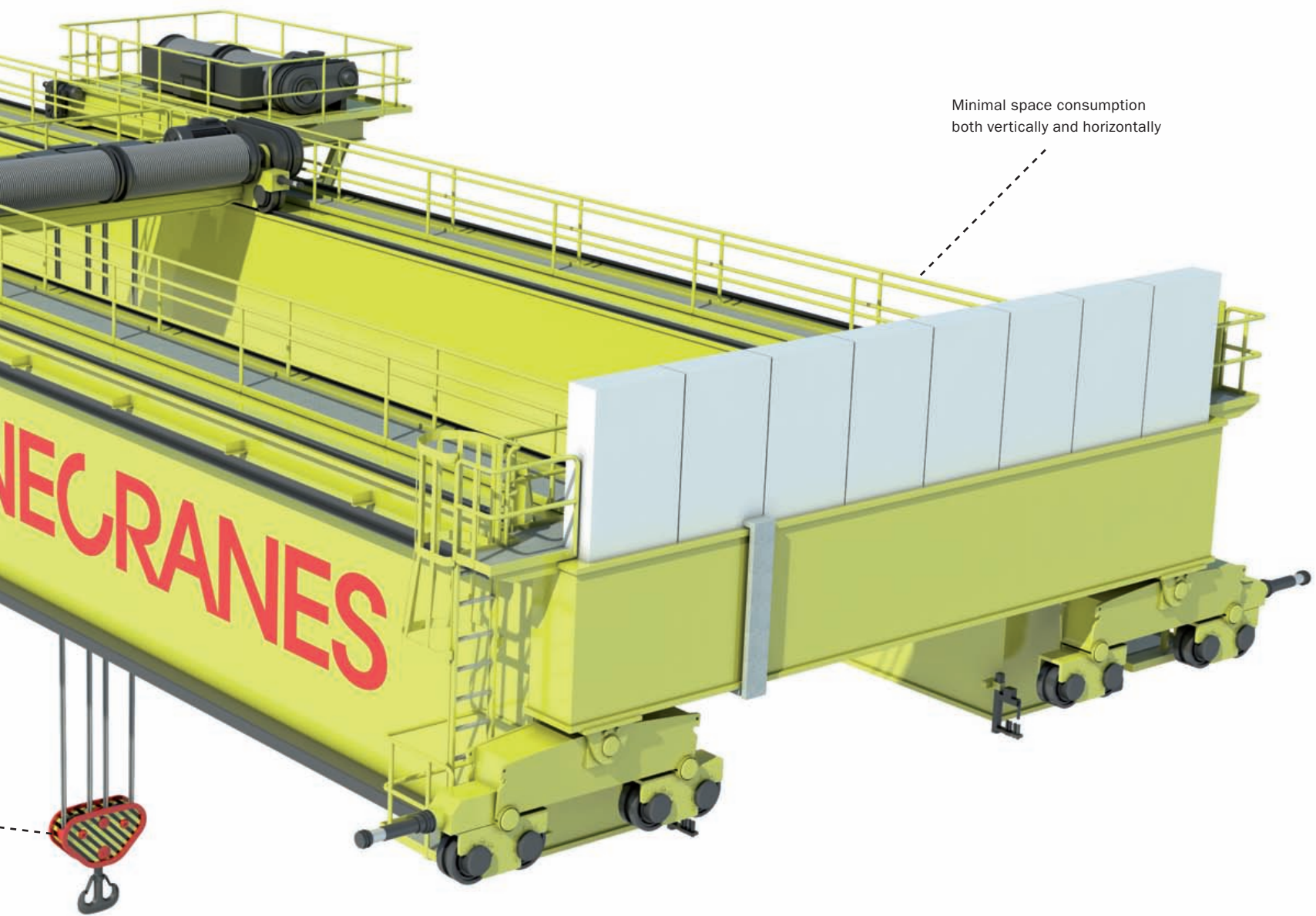

Minimal space consumption
both vertically and horizontally

GOLIATH GANTRY CRANE

The biggest ship block you have to lift defines the Goliath lifting capacity you need. You must make a basic decision: do you want one large Goliath, or do you want the flexibility of having two smaller Goliaths on your dry dock? The safety of two Goliaths in tandem use is an important factor to consider in this case.

Tandem use

The Konecranes design allows the cranes to be driven very close to each other when working in tandem. Our master-and-slave concept gives full control over both cranes to a single operator, from one control station. The slave crane follows every move made by the master crane, precisely and without delay, eliminating the safety hazards associated with traditional two-operator driving.

Lifting capacity	Flyweight	Welterweight	Heavyweight
Nominal capacity	250–700 tons	700–1200 tons	1200–2200 tons
Upper trolley total	55–100%	55–100%	55–100%
Upper trolley load unbalance	50–100%	50–100%	50–100%
Lower trolley	60–100%	60–100%	60–100%
Auxiliary hoist	20–50 tons	20–50 tons	20–50 tons
Service hoist	6–10 tons	6–10 tons	6–10 tons
Product concept and features			
Recommended girder concept	Double	Single	Single
Load rotation	Option	Standard	Standard
Speed change reducers	Option	Option	Standard
Elevator	Standard	Standard	Standard
Cabin	Leg-mounted	Trolley-mounted	Trolley-mounted
Main dimensions			
Span	60–230 m	50–230 m	50–230 m
Lifting height (maximum)	Up to 90 m	Up to 120 m	Up to 120 m
Lifting height (nominal)	Up to 82 m	Up to 112 m	Up to 112 m
Hook traverse	2 m	2–8 m	2–8 m
Buffer to buffer	Appr. 30 m	Appr. 46 m	Appr. 58 m
Typical speeds			
Gantry travel	30 m/min	30 m/min	30 m/min
Upper trolley traversing	30 m/min		
Upper trolley hoisting / no load	10–20 m/min	10–20 m/min	10–20 m/min
Upper trolley hoisting / with load	6–12 m/min	3–8 m/min	3–6 m/min
Lower trolley traversing / with load	30 m/min	30 m/min	30 m/min
Lower trolley hoisting / no load	10–20 m/min	10–20 m/min	10–20 m/min
Lower trolley hoisting / with load	6–12 m/min	3–8 m/min	3–6 m/min
Auxiliary hoist speed	10–40 m/min	10–40 m/min	10–40 m/min
Service hoist	5–25 m/min	5–25 m/min	5–25 m/min
Electrical systems			
Crane power supply	Cable reel	Cable reel	Cable reel
Trolley power feed	Festoon/Cable track	Festoon/Cable track	Festoon/Cable track
Drive and control system	Konecranes AC	Konecranes AC	Konecranes AC
Maintenance			
Crane Monitoring System	Standard	Standard	Standard
Remote diagnostics	Option	Option	Option

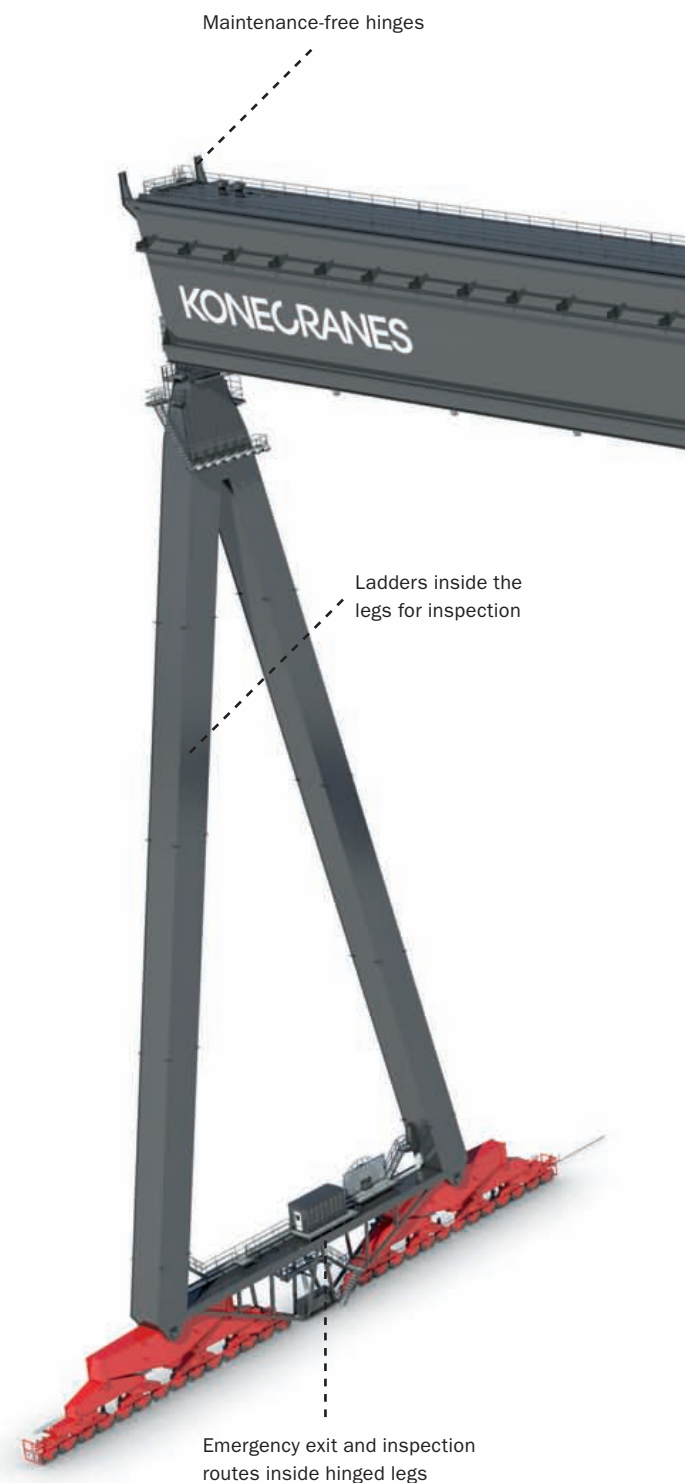



Girder design

Konecranes offers both single-girder and double-girder designs: both are used around the world by our customers. One is not generally better than the other. However, when the span of the crane exceeds 100 m, the advantages of the single-girder design become apparent. The most important advantage is our standard maximal flex of $1/800 \times \text{span}$, which can be achieved using much less steel with the single-girder design than with the double-girder design.

Thanks to the rigidity of the single girder design, single-girder Goliaths allow a greater load unbalance between the upper trolley hooks.

Double girder

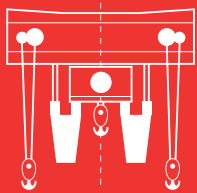

Single girder

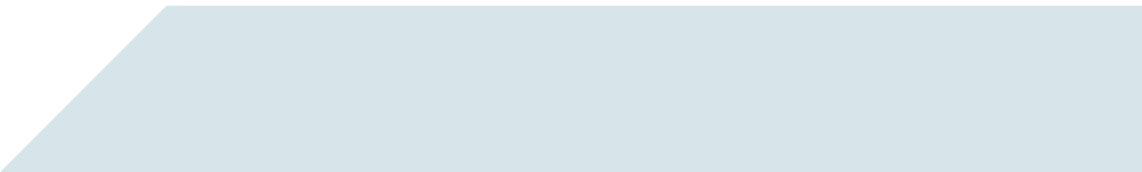
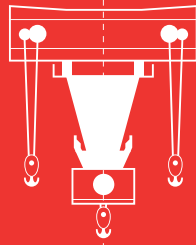

SINGLE BOOM SHIPYARD CRANE

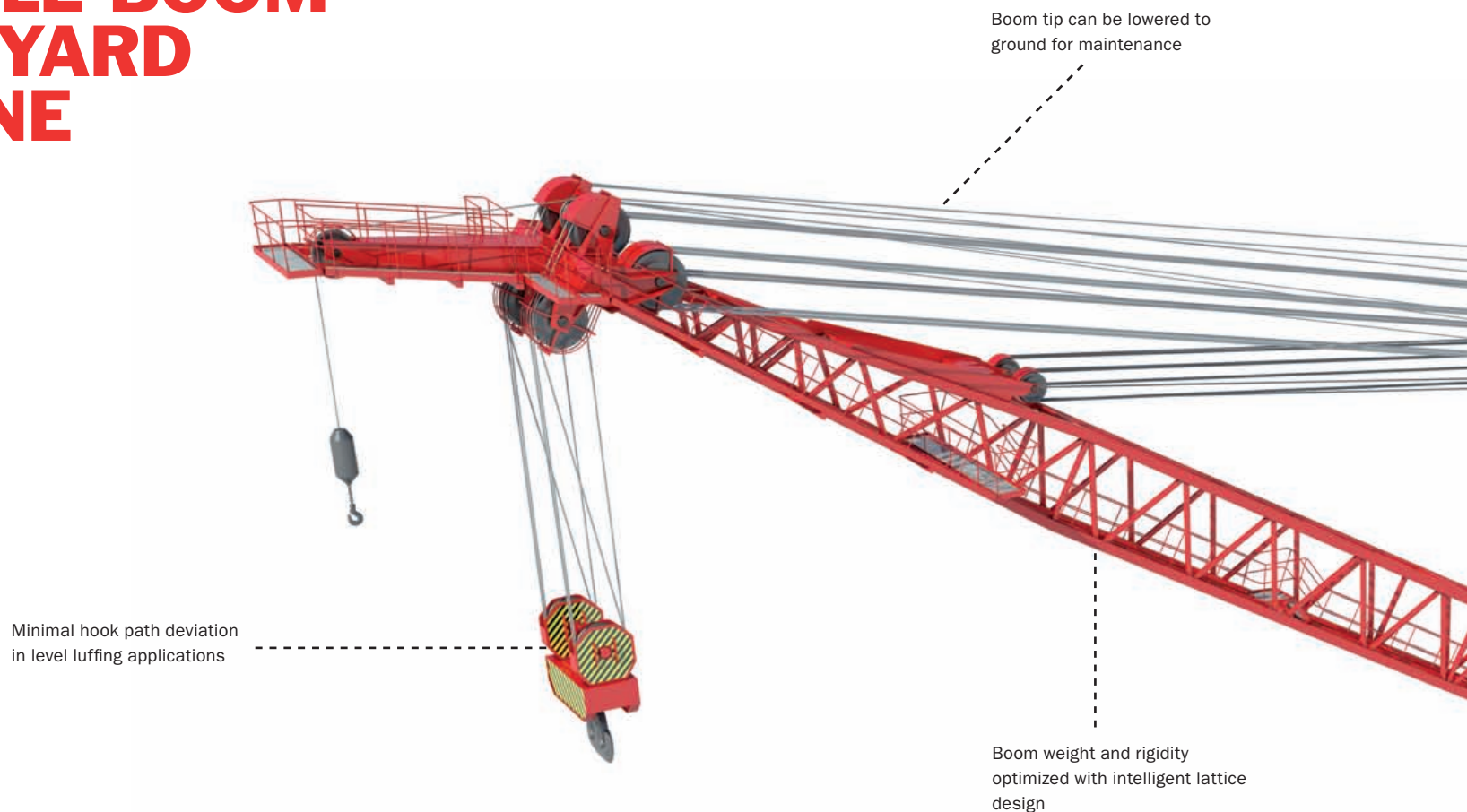

Lifting capacity	Flyweight	Welterweight	Heavyweight
Rated capacity	22–50 tons	50–100 tons	100–350 tons
Auxiliary hoist	5–15 tons	10–30 tons	10–50 tons
Service hoist	2–6 tons	2–6 tons	2–6 tons
Main dimensions			
Span	Down to 6 m	Down to 8 m	Down to 10 m
Lifting height above rail	Up to 70 m	Up to 120 m	Up to 120 m
Lifting height below rail	Up to 30 m	Up to 30 m	Up to 30 m
Outreach	Up to 85 m	Up to 85 m	Up to 85 m
Speeds			
Gantry travel speed	30–50 m/min	30–45 m/min	30–40 m/min
Luffing speed	15–30 m/min	15–25 m/min	15–20 m/min
Slewing speed	1.00 r/min	0.75 r/min	0.50 r/min
Hoisting speed with nominal load	10–30 m/min	7.5–20 m/min	5–15 m/min
Hoisting speed with no load	25–50 m/min	20–35 m/min	20–30 m/min
Auxiliary hoist speed with nominal load	45–70 m/min	40–60 m/min	35–55 m/min
Auxiliary hoist speed with no load	60–90 m/min	55–85 m/min	50–80 m/min
Electrical systems			
Crane power supply	Cable reel	Cable reel	Cable reel
Drive and control system	Konecranes AC	Konecranes AC	Konecranes AC
Maintenance			
Crane Monitoring System	Standard	Standard	Standard
Remote diagnostics	Option	Option	Option

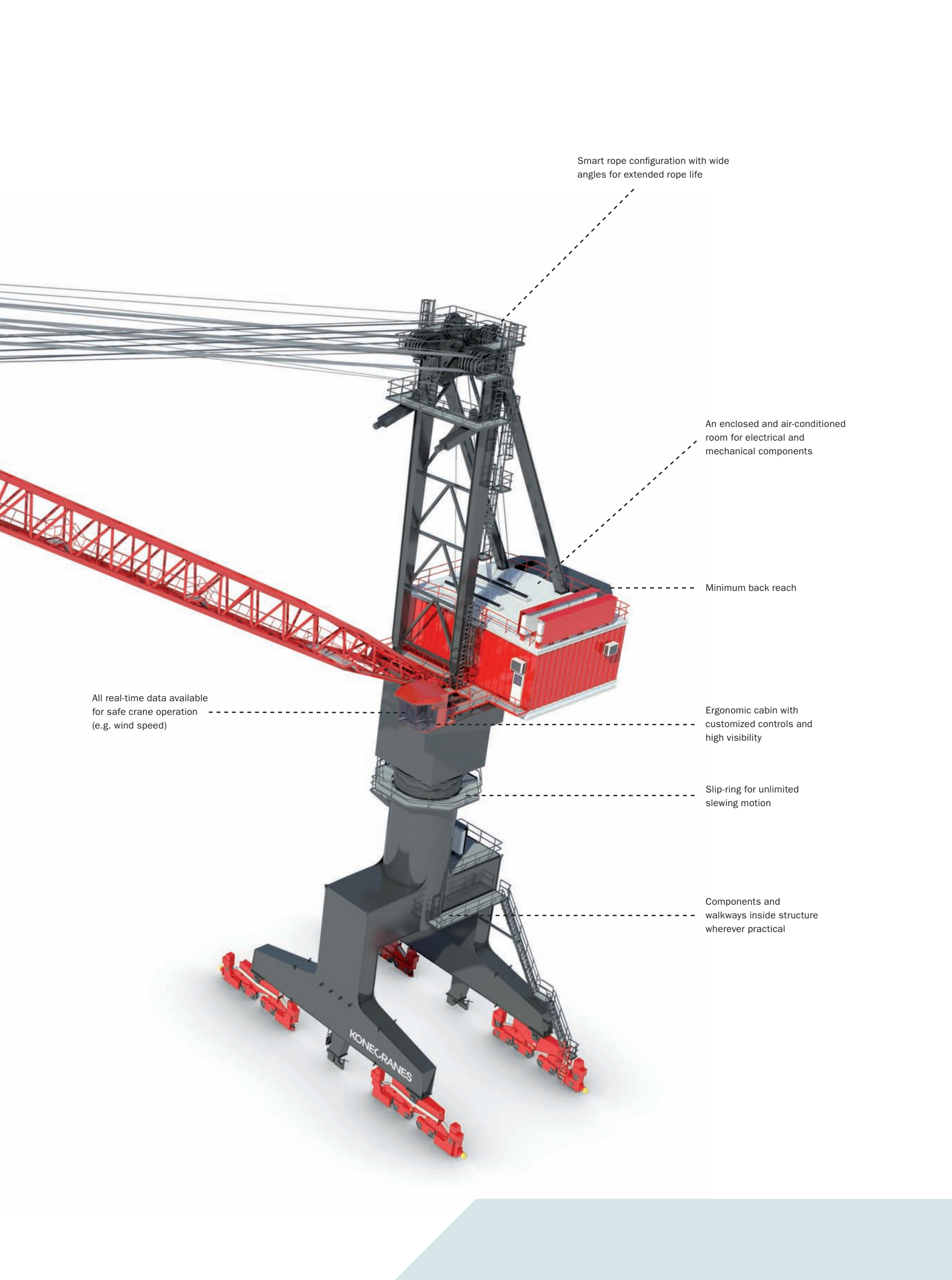

Smart rope configuration with wide angles for extended rope life

An enclosed and air-conditioned room for electrical and mechanical components

Minimum back reach

All real-time data available for safe crane operation (e.g. wind speed)

Ergonomic cabin with customized controls and high visibility

Slip-ring for unlimited slewing motion

Components and walkways inside structure wherever practical

KONECRANES

DOUBLE BOOM SHIPYARD CRANE

Enclosed and air-conditioned
room for electrical and
mechanical components

Minimum back reach

Ergonomic cabin with
customized controls and
high visibility

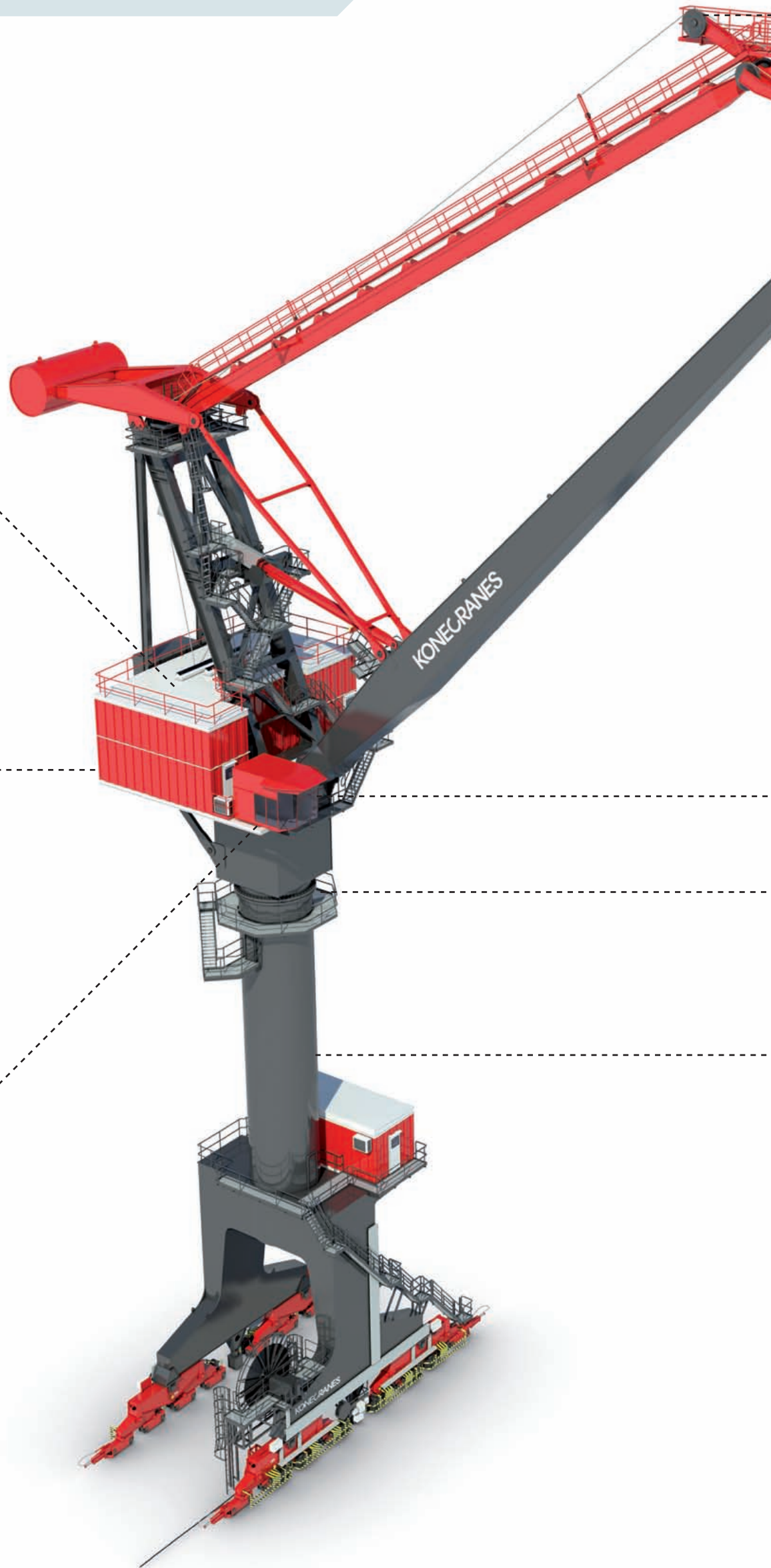

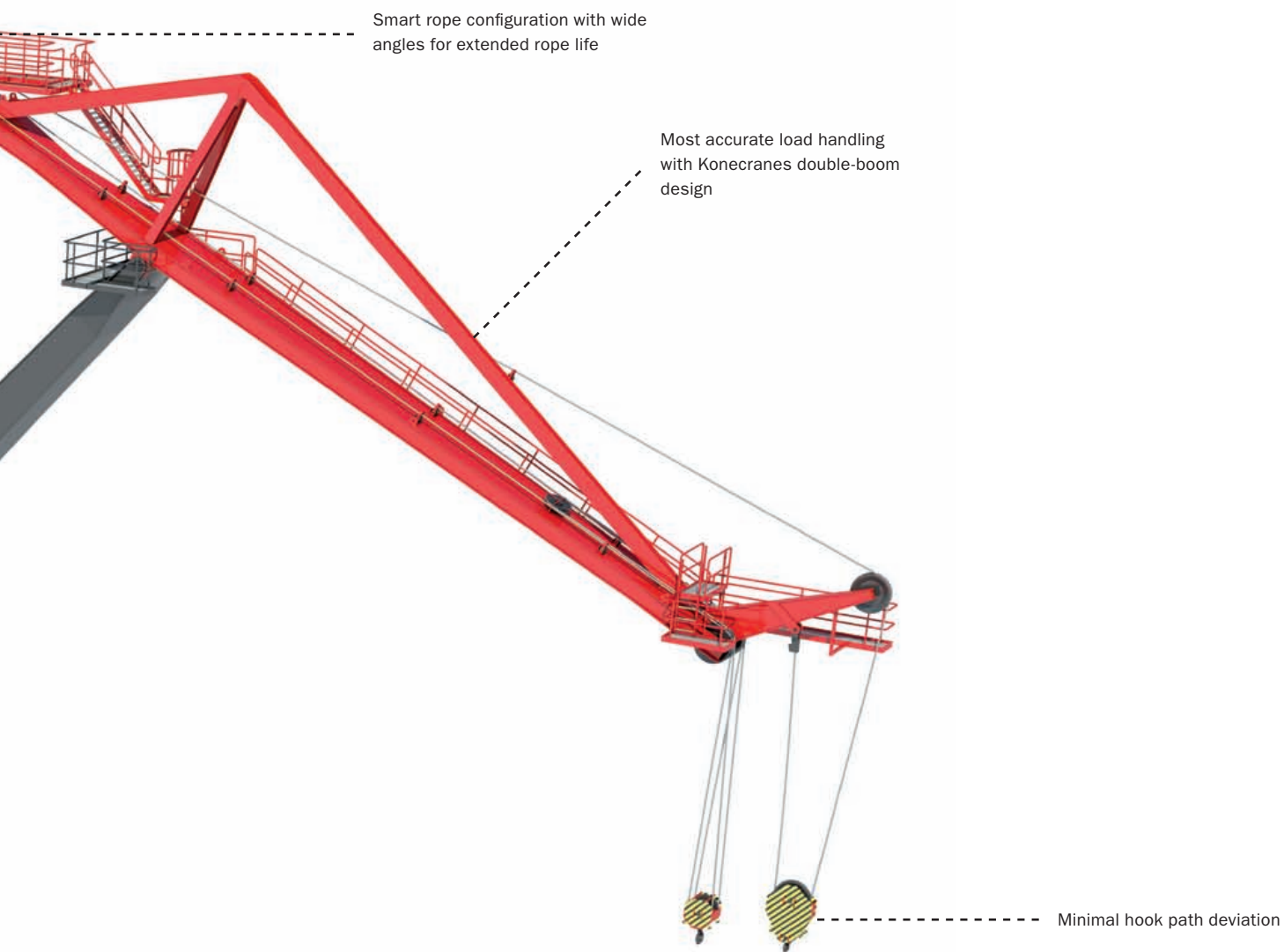

Smart rope configuration with wide angles for extended rope life

Most accurate load handling with Konecranes double-boom design

Minimal hook path deviation

All real-time data available for safe crane operation (e.g. wind speed)

Slip-ring for unlimited slewing motion

Components and walkways inside structures wherever practical

Lifting capacity	Flyweight	Welterweight	Heavyweight
Rated capacity	22–50 tons	50–100 tons	100–250 tons
Auxiliary hoist	5–15 tons	10–30 tons	10–50 tons
Service hoist	2–6 tons	2–6 tons	2–6 tons
Main dimensions			
Span	Down to 6 m	Down to 8 m	Down to 10 m
Lifting height above rail	Up to 70 m	Up to 120 m	Up to 120 m
Lifting height below rail	Up to 30 m	Up to 30 m	Up to 30 m
Outreach	Up to 70 m	Up to 70 m	Up to 70 m
Speeds			
Gantry travel speed	30–50 m/min	30–45 m/min	30–40 m/min
Luffing speed	15–30 m/min	15–25 m/min	15–20 m/min
Slewing speed	1.00 r/min	0.75 r/min	0.50 r/min
Hoisting speed with nominal load	10–30 m/min	7.5–20 m/min	5–15 m/min
Hoisting speed with no load	25–50 m/min	20–35 m/min	20–30 m/min
Auxiliary hoist speed with nominal load	45–70 m/min	40–60 m/min	35–55 m/min
Auxiliary hoist speed with no load	60–90 m/min	55–85 m/min	50–80 m/min
Electrical systems			
Crane power supply	Cable reel	Cable reel	Cable reel
Drive and control system	Konecranes AC	Konecranes AC	Konecranes AC
Maintenance			
Crane Monitoring System	Standard	Standard	Standard
Remote diagnostics	Option	Option	Option

FLOATING DOCK CRANE

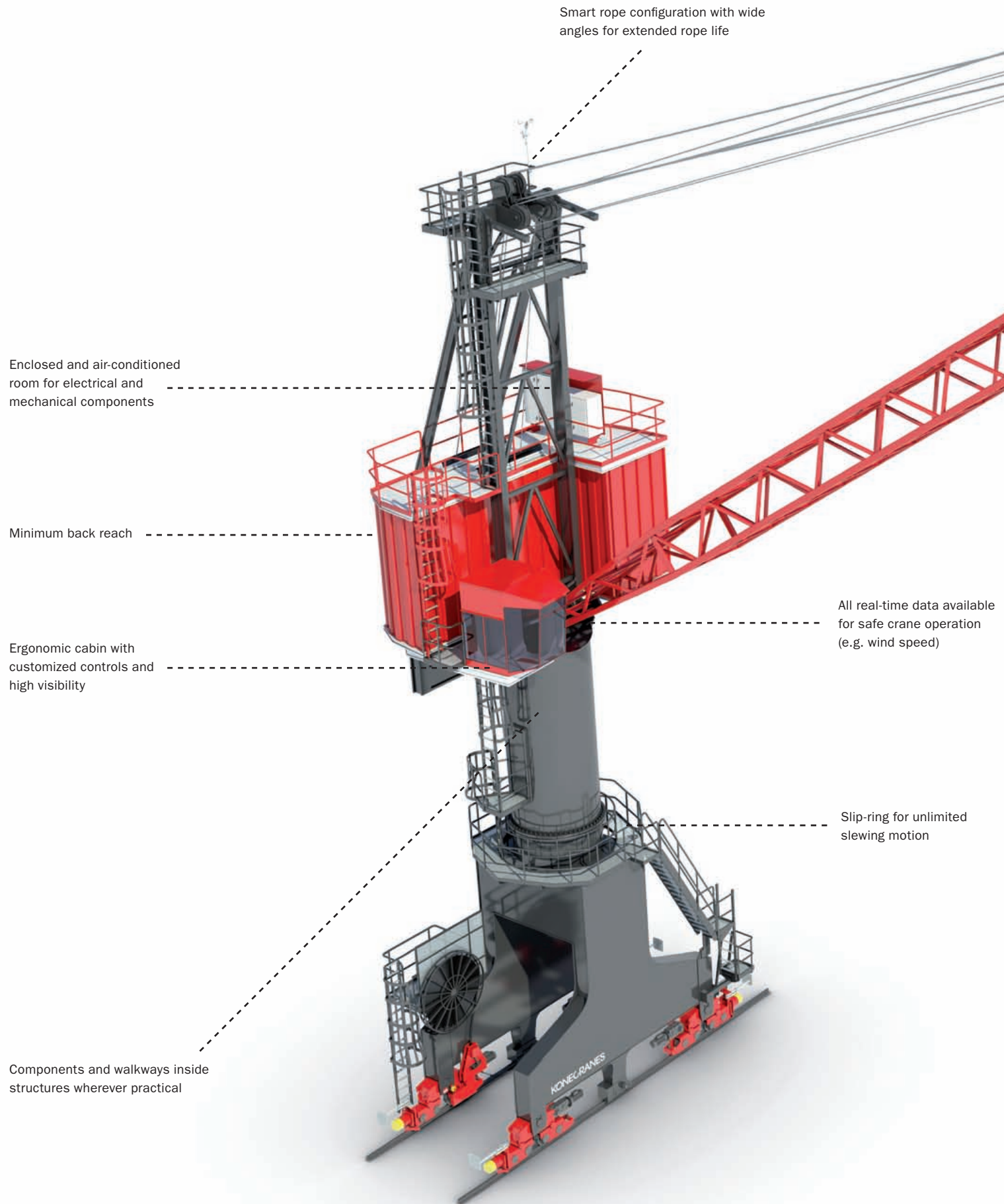

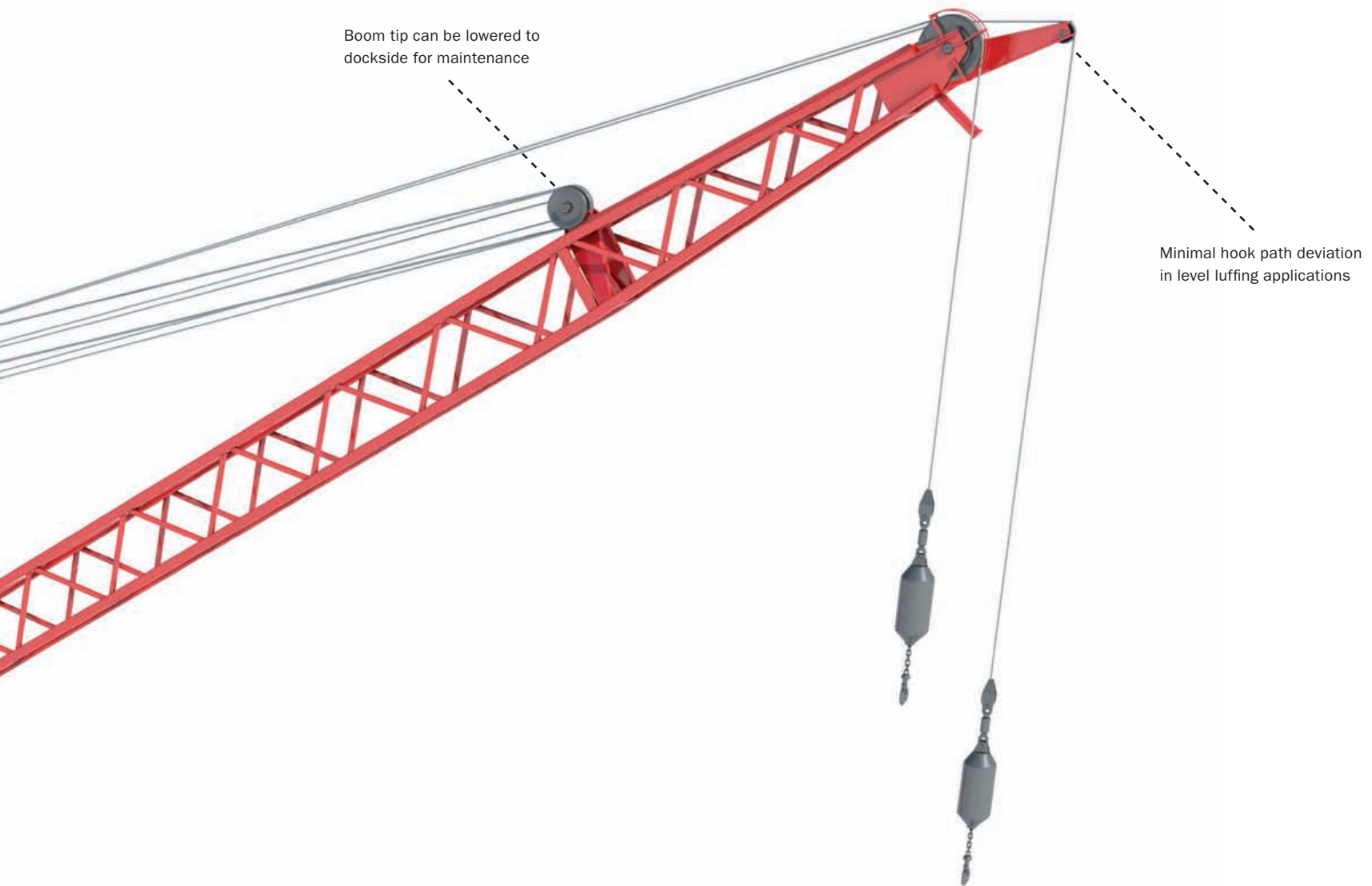

Lifting capacity	Standard	Tailored
Nominal load	10–20 tons	Up to 60 tons
Main dimensions		
Outreach	20–30 m	Up to 40 m
Lifting height above rail	25–30 m	Up to 45 m
Lifting height below rail	15–25 m	Up to 30 m
Rail span	5–8 m	Down to 4 m
Portal clearance	4–6 m	Up to 8 m
Buffer to buffer	9–12 m	Down to 8 m
Speeds		
Gantry travel speed	30 m/min	Up to 40 m/min
Luffing speed	30 m/min	Up to 40 m/min
Hoisting speed, full load	7 m/min	Up to 30 m/min
Hoisting speed, no load	14 m/min	Up to 50 m/min
Slewing	1 rpm	Up to 1.5 rpm
Electrical systems		
Crane power supply	Cable reel	Cable reel
Drive and control system	Konecranes AC	Konecranes AC
Maintenance		
Crane Monitoring System	Standard	Standard
Remote diagnostics	Option	Option

LIFT TRUCKS

FORK LIFT TRUCKS 10–60 TONS

Technical data	Small	Medium	Large
Lifting capacity	10–18 tons	18–25 tons	28–60 tons
Lifting height	3–12 m	3–15 m	4–15 m
Lifting speed	0.30–0.60 m/s	0.25–0.40 m/s	0.15–0.40 m/s
Drive speed	30–30 km/h	27–29 km/h	22–24 km/h
Engine	EU stage 2 or 3a / US EPA Tier 2 or 3 (6-cylinder, turbo-charged, CanBus)		
Hydraulics	Load sensing, low energy, low fuel consumption		
Lift equipment	Forks, container spreaders, coil rams, paper clamps etc.		

EMPTY CONTAINER LIFT TRUCKS 8–10 TONS, 4–8 HIGH

Technical data	Small	Medium	Large
Lifting capacity	8 tons	9 tons	10 tons
Stacking height	4–6 containers	4–8 containers	4–8 m
Lifting speed	0.45–0.52 m/s	0.73–0.63 m/s	0.73–0.63 m/s
Drive speed	30–30 km/h	30–30 km/h	30–30 km/h
Engine	EU stage 2 or 3a / US EPA Tier 2 or 3 (6-cylinder, turbo-charged, CanBus)		
Hydraulics	Load sensing, low energy, low fuel consumption		
Spreaders	Sidelift 20–40 ft (45–53 ft in 40 ft castings), single or double lift		
Functions	Sideshift $\pm 300/\pm 600$ mm, MPS pile slope 0–225 mm		

LADEN CONTAINER LIFT TRUCKS 22–45 TONS, 3–5 HIGH

Technical data	Small	Medium	Large
Lifting capacity	22–28 tons	33–35 tons	38–45 tons
Stacking height	3–4 containers	3–5 containers	3–5 m
Lifting speed	0.27–0.40 m/s	0.21–0.35 m/s	0.21–0.35 m/s
Drive speed	22–24 km/h	22–24 km/h	22–26 km/h
Engine	EU stage 2 or 3a / US EPA Tier 2 or 3 (6-cylinder, turbo-charged, CanBus)		
Hydraulics	Load sensing, low energy, low fuel consumption		
Spreaders	Toplift 20–40 ft (45–53 ft in 40 ft castings), single lift only		
Functions	Sideshift ± 200 mm, MPS pile slope ± 4.8 deg, slew ± 6.0 deg, reach 0–240 mm		

ALL FORK LIFT TRUCKS AND CONTAINER LIFT TRUCKS

Engine approvals	EU stage 2 or 3a / US EPA Tier 2 or 3
Engine types	6-cylinder, turbo-charged, intercooler, electronic controls, CanBus
Transmission	Fully automatic, electronic-hydraulic shift, reverse protection, CanBus
Hydraulics	Load-sensing, power-on-demand, low-energy, low fuel consumption
Optional controls	Remote service function (via GSM), error code data log, ECO-driving, multi-driver login, mini-steering, electronic weight scale, Fleet Management System (FMS)

Large selection of lift masts makes optimization easy

Load-sensing hydraulics maximize fuel efficiency and reduce emissions

Quick-change system for forks and other attachments allows handling of huge range of materials

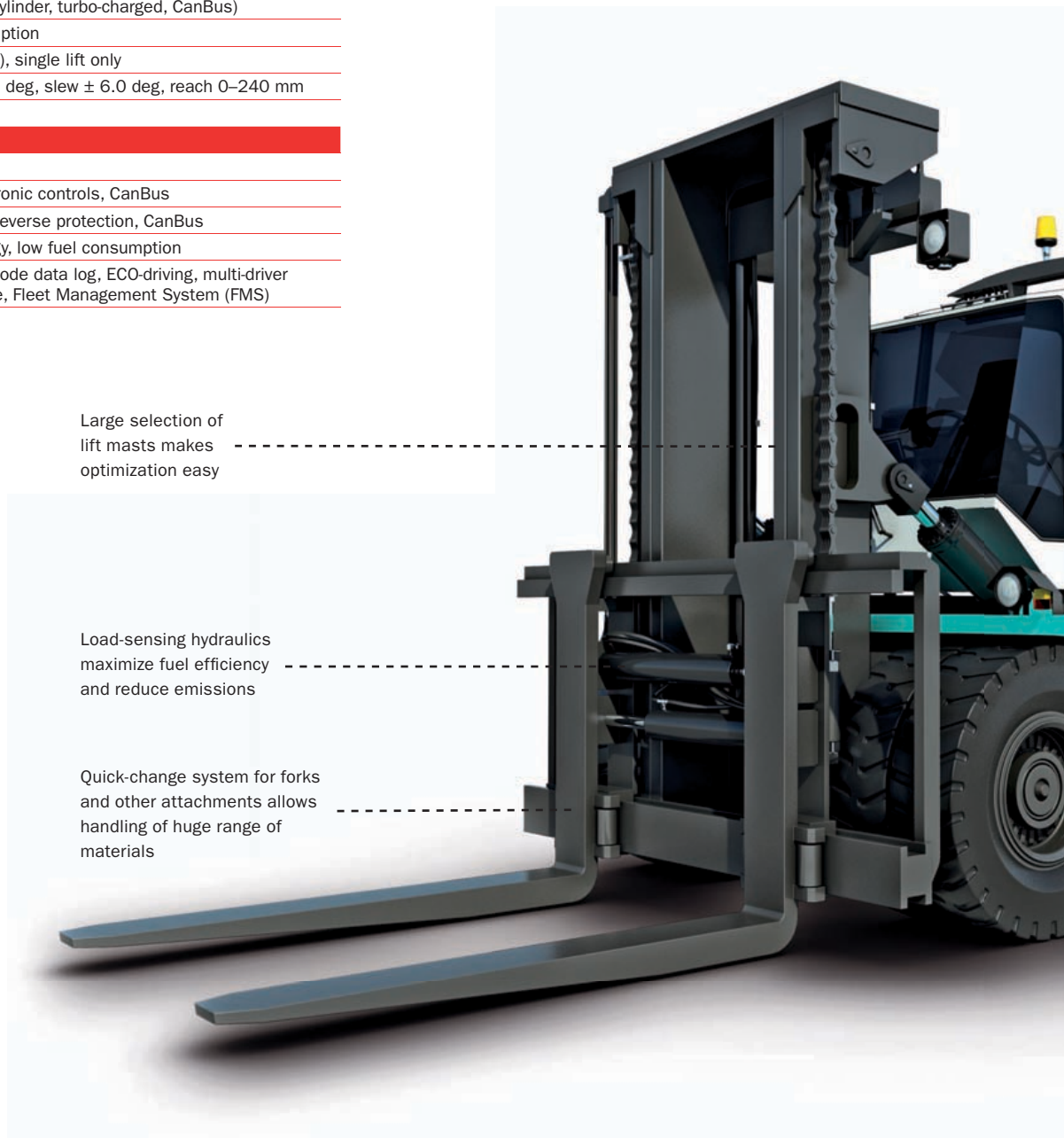



Lift masts adapted to container handling. Fewer hoses and cables for less maintenance and more uptime.

Maintenance-free brakes with continuous oil cooling

Wide drive axle and long wheel base for maximum stability

Extended service interval reduces maintenance costs

Strong box-type chassis provides higher lifting capacity



CanBus technology monitors engine and transmission for better reliability

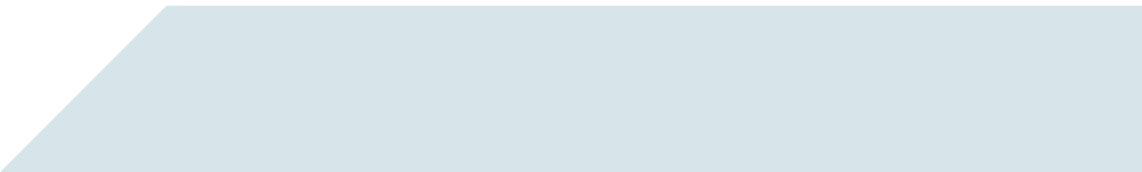

BETTER SERVICE MEANS A BETTER CRANE

Good service is essential to keep a crane running efficiently, and will greatly extend the life of your equipment. With our professional evaluation, preventive maintenance and consultation services, we can tailor a service package designed specially for the needs of your shipyard.

Whether you require performance-based maintenance or complete materials outsourcing, Konecranes has the experience and resources to help you reach your business objectives.

CRANE MODERNIZATIONS

Extending the lifetime of a crane is sometimes smarter than investing in a completely new one. The performance, safety, and reliability of your old crane can be significantly increased through modernization. You can get a complete mechanical and electrical upgrade, along with testing and commissioning.

ADVANCED DIAGNOSTICS

Inspection and maintenance can include an extensive range of advanced diagnostic services. In particular, we recommend our Crane Reliability Survey, an engineering assessment of the current condition and future maintenance needs of your cranes; RailQ, which assesses the crane runway and provides a comprehensive report; and RopeQ, which informs you about the condition of your wire ropes (including the interior), and when they need to be changed.



MAINTENANCE

To get a consistently high level of performance from your crane, regular planned maintenance is a must. It will help improve safety and reliability, reduce overall operating costs, and ensure that your needs are met as they change over time.

INSPECTION SERVICES

Your crane is analyzed right down to component level, including recommendations on how to improve safety, reliability, and cost optimization. With regular standardized inspections, you can ensure the fulfillment of statutory requirements and help reduce the risk of breakdowns.

SPARE PARTS FOR ALL MAKES AND MODELS

As a global supplier of spare parts for shipyard lifting equipment, Konecranes can support you with an extensive distribution network, part identification, order handling, high availability, and fast delivery. If required, we can also promptly design and manufacture a customized spare part just for you.

AND MORE

Konecranes provides many other services such as crane relocations and rail grinding, both typical for shipyards. If you need something for your crane, even if it's not listed here, please ask.

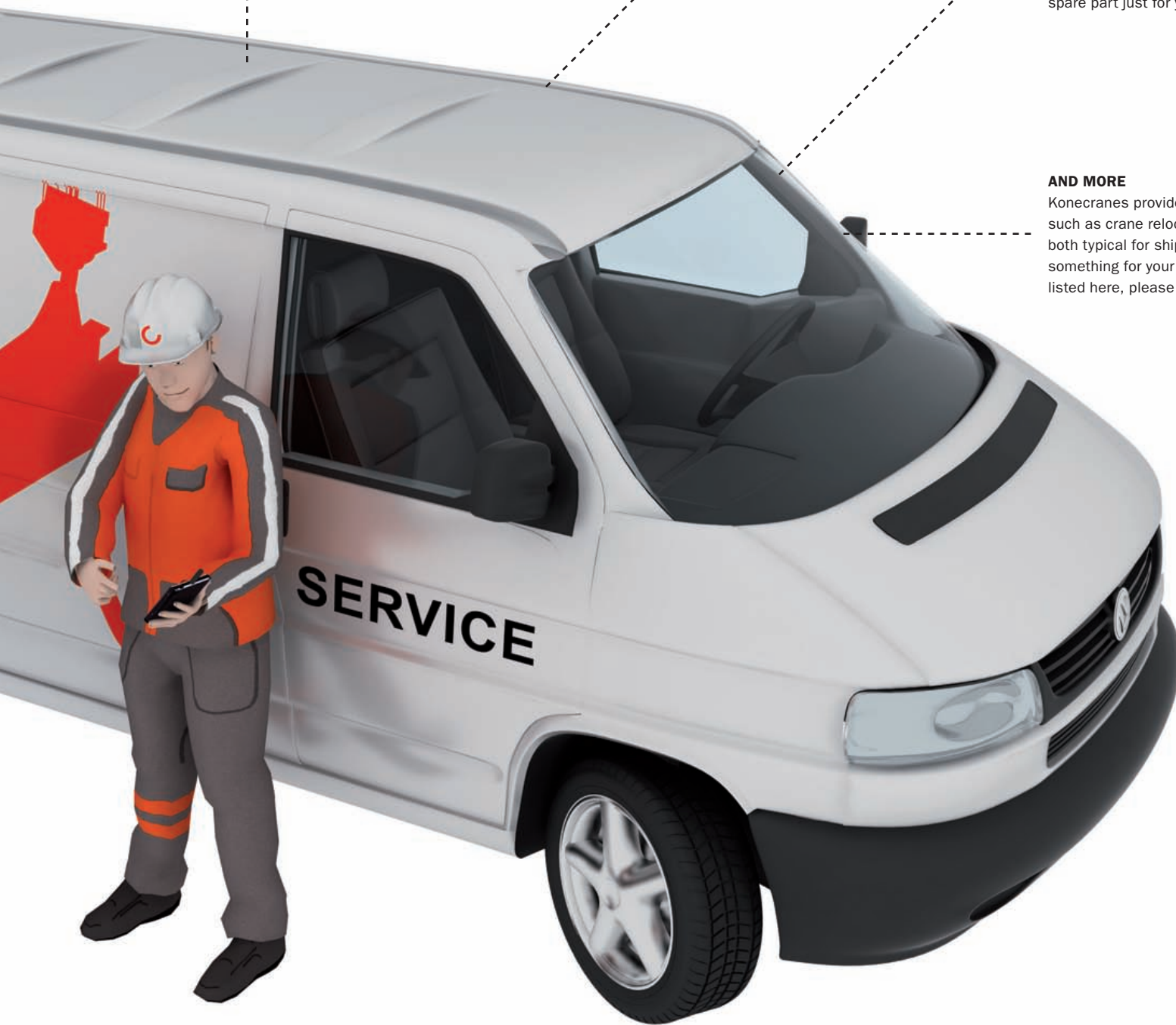







An aerial photograph of a shipyard at sunset. The sun is low on the horizon, casting a golden glow over the water and the industrial structures. In the foreground, several thick, dark cables of a crane run vertically down the frame. The shipyard below is filled with various structures, including large storage tanks and buildings. A few ships are visible in the water.

SATISFIED CUSTOMERS

At Konecranes, we understand that every customer is unique. Shipyards differ a lot in space available, output capacity, number of personnel, local weather, and many other variables. So we would like to show you some examples of how shipbuilders around the world are using our lifting equipment in their own special way.

BIG IN BRAZIL

Opened in 2008, the Estaleiro Atlântico Sul (EAS) shipyard aims to become one of the most important global players in the business. Located in the Suape area just south of the city of Recife on the easternmost tip of Brazil, it is the biggest and most modern naval and offshore construction and repair shipyard in the southern hemisphere, processing 160 thousand tons of steel per year.

In only a few years, the strategically located shipyard has become very important to the region. Not just building vessels for international sale, and repairing ships on passing trade routes, it also constructs and repairs offshore platforms, especially for the important oil and gas producing areas in the Gulf of Mexico and near the coast of West Africa.

With the sheer volume of work it must complete, the shipyard has to work fast. The large plant size allows for a substantial reduction in building times as ships are built from prefabricated hull blocks.

To lift these blocks, EAS ordered two gigantic Goliath Gantry Cranes, equipped with the latest in Konecranes lifting technology. Both of these cranes are 100 meters high, span 164 meters, and can lift up to 1,500 tons each. Konecranes also delivered about 50 overhead industrial cranes of varying capacities.

Alone, these cranes can easily lift the average block of about 1,000 tons. But some construction uses megablocks, which are even bigger. Customers want their ships quickly and working with megablocks is essential for that international competitive edge. Larger blocks mean fewer blocks, and greater speed. The ship hull can be welded together faster in dry dock, floated and moved along to the outfitting quay. The combined muscle of the two Goliaths can lift up to 3,000 tons.

Angelo Bellelis, CEO of EAS, is very pleased with the Konecranes products and solutions and is strongly considering giving the company an even more central role in future projects. “Konecranes provides us with very, very high-level technology,” Bellelis says. “Next time we could even put the responsibility for the whole crane project on Konecranes as the main contractor.”

Shipbuilding has been very successful here, but there is more to the story than that. The Atlântico Sul shipyard has helped change the country’s social and economic structure. It has revitalized the Brazilian shipbuilding industry after 18 years of recession.

Part of this has come from providing the local area with 4,700 jobs. Many of those people work with the equipment in the shipyard, including the two Goliath Gantry Cranes. The operators and maintenance crew like the cranes, admiring the level of technology they work with, as well as the keen attention to safety that has been built into the crane design.

Crane Operator Moises Batista Bezerra sums it up: “This is a great piece of equipment,” he says.

Left: The Goliath Gantry Crane puts the Atlântico Sul shipyard in the forefront of the global shipbuilding industry.

Top right: The EAS shipyard provides the Suape area with thousands of jobs. Wellington Silva Ferreira is one of EAS’ 4,700 employees.

Bottom right: November 27, 2010, the two Goliath cranes muscle up a load of 2,500 tons. It’s a lifting record.





“The Goliath Gantry Crane is really the most important piece of equipment in our shipyard. It is the key to success here.”

James Murray, Supply Manager, Atlântico Sul



WINNING THE GAME WITH A BIGGER CRANE

Goliath Gantry Cranes from Konecranes have tripled production at South Korean shipyard Hyundai Samho Heavy Industries Co. Ltd. Located in Mokpo, in the southwest of South Korea, the shipyard is owned by the Hyundai Heavy Industries Group, the largest shipbuilding company in the world.

“Before they got the Goliath cranes, they launched one ship every three months,” says Sang-Won Nam, Konecranes’ shipyard sales agent in South Korea. “Now they do so every month.”

The ten shipyards at Mokpo are very important for the regional economy, and take up a lot of the waterfront. The streets in the area are wide enough to accommodate heavy load transporters, which are used to move ship blocks from subcontractors to a shipyard assembly line, where the Goliath Gantry Crane hoists them into place.

Even from miles away, the four giant Goliath cranes of the Hyundai Samho Shipyard dominate the landscape with their red A-frames, each over 100 meters high. The largest one is 142 meters tall, has a span of 165 meters, and a capacity of 1,650 tons.

To get to the mechanical guts of one of these cranes, maintenance personnel board a rack-and-pinion type elevator and travel up inside one of the legs. The hoisting ropes, which look thin from the ground, have the circumference of a woman’s ankle. Precise control mechanisms move loads with precision down to the last millimeter.

Konecranes offers cranes to fit every customer’s needs. Whether it’s hoisting capacity, speed, crane width, height, or the number of hoists, everything can be adjusted for local conditions and individual customer requirements. Or a customer might prefer a turnkey delivery, which takes away the stress of deciding each variable, and brings a ready-made crane to the shipyard. Customers also have the opportunity to manufacture part or all of the crane themselves based on Konecranes’ designs.

Since Hyundai Samho Heavy Industries Co. also builds cranes, it was natural for the company to manufacture most of their Goliath Gantry Cranes. Konecranes delivered the hoists, lifting mechanisms, and control systems. It takes 14 to 16 months to build such a crane. The project was supervised by Konecranes experts.

Shipbuilding slowed down during the recent global financial crisis, but it has been experiencing a comeback as economies recover and international trade expands again. Korea produces more ships than any other country in the world, and the Hyundai Samho shipyard is the fourth-largest in the world, with over 10,000 employees. Production is concentrated on tankers, bulk carriers, and container ships.

Top: Hyundai acquired the former Halla Shipyard in 2003. The Hyundai Samho shipyard now employs over 10,000 people.
Bottom: The biggest and tallest of the Goliaths is the 1,200-ton crane delivered in the spring. The giant has a span of 142 meters and a maximum height of 124 meters.





900 TON

“The crane moves loads with precision down to the last millimeter.”







“The Hyundai Samho shipyard is the fourth-largest in the world, with over 10,000 employees.”



For many Western shipping company customers, one of the most attractive features of Korean shipbuilding is the priority it places on worker safety. Big orders can be won or lost depending on accident statistics.

The importance of this is highlighted both in theory and practice. The main administrative building of the Hyundai Samho shipyard displays a sign saying “Safety is a promise to make everyone happy”.

A casual glance at any welder or fitter at work will see them kitted out in spark-protected clothing, a dust mask, and safety shoes. Nobody is allowed to move around on-site without a helmet.

Safety is also prioritized in the Konecranes Goliath design.

To keep the structure steady, the crane moves along two rails carried by 96 wheels, each of which can support 90 tons. There are 42 electric motors to ensure full control over lifting and movement. Current is fed to the crane through a wrist-thick cable that automatically reels in and out as the crane moves along the dock. The Konecranes single girder solution, lighter and stiffer than a double girder crane, helps to prevent load sway.

But it doesn't stop there. Suspended almost 100 meters up over empty space, the operator's cabin is fitted with wall-to-wall carpeting, air conditioning, and a television. Good ergonomics ensure that the operator is comfortable, which contributes to safer load handling.

Goliaths have become very popular in recent years. Although the crane was introduced to market in the 1960s, some 60 percent of the 66 Goliath cranes that Konecranes has sold since 1972 have been delivered since 2006. Thirty-three, or half of all the Goliaths supplied by Konecranes worldwide are now operating in South Korea.

Konecranes understands the importance of negotiating and selling in the local language with an understanding of local customs, so sales agent Sang-Won Nam does an essential job in South Korea. “Crane contracts include a great number of details, which both parties must really understand for the results to be ideal for both of them,” says Jussi Rautiainen, in charge of the shipyard crane business at Konecranes.

None of the Konecranes Goliaths has been decommissioned due to aging. The basic steel structure can last pretty much forever, assuming that professional inspection and service routines are carried out regularly. The electrical equipment is normally updated every twenty years to keep up with technological development.

Left: Owing to typhoons, cranes used in South Korea must withstand wind speeds of 60 meters per second (134 miles/hour).

Right: The Hyundai Samho Shipyard runs its own service and repair department with hundreds of employees.

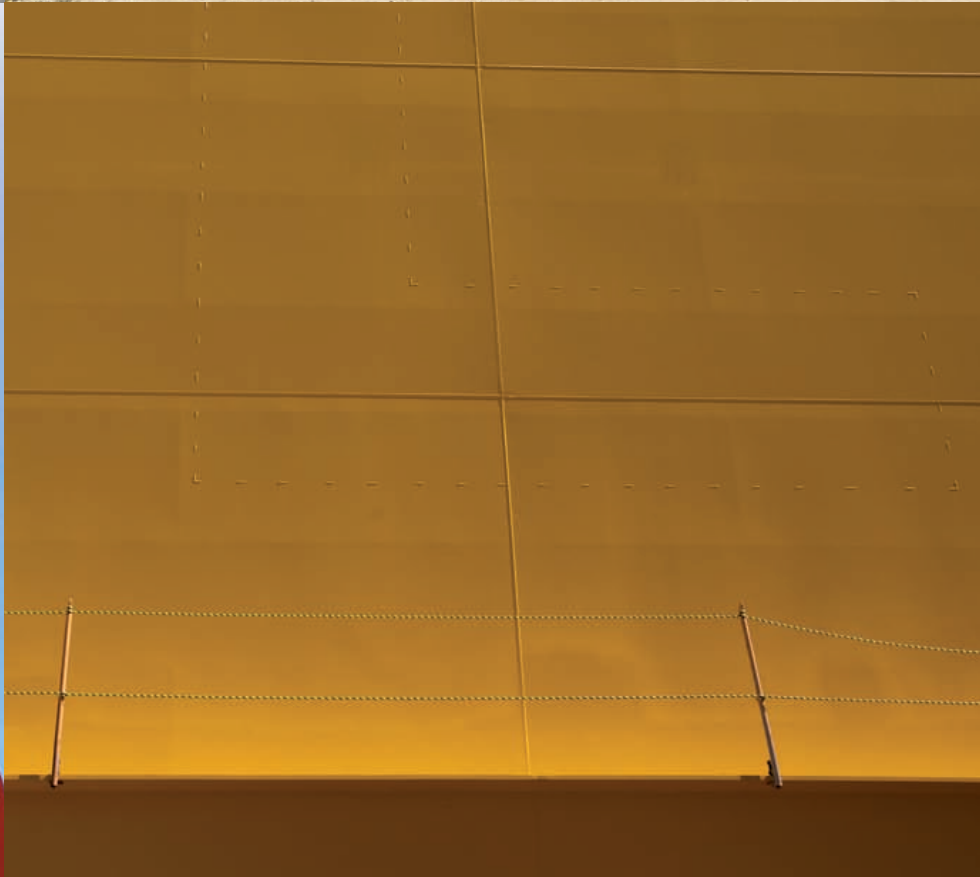

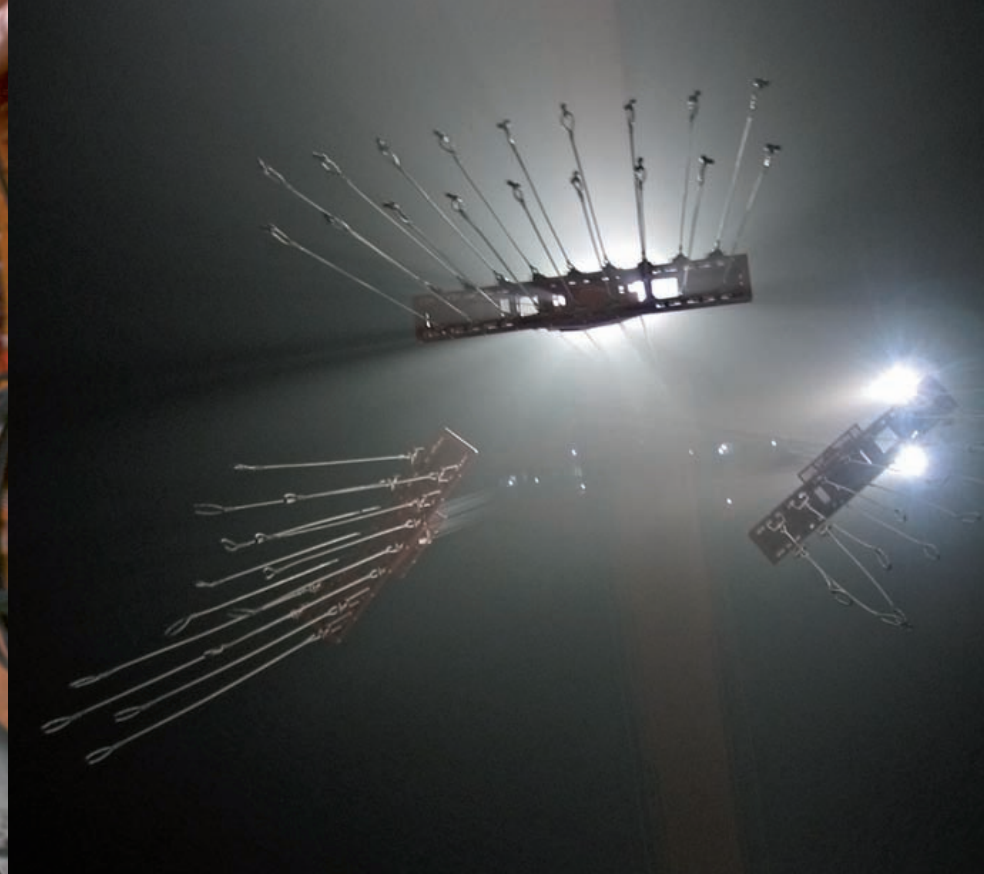

IT JUST WORKS

Konecranes customers like our products because they know our long background in lifting and specific industry knowledge combine to engineer a crane tailored for their particular needs. They enjoy speedy, localized service from our worldwide network that ensures their cranes keep running for many years of productive use.

Whether your shipyard is big, building hundreds of ships per year, or small, providing specialized services to your area, Konecranes can help you lift your business.



WHY CHOOSE KONECRANES?

Konecranes is a world-leading group of Lifting Businesses™, serving a broad range of customers, including manufacturing and process industries, shipyards, ports and terminals. Konecranes provides productivity-enhancing lifting solutions as well as services for lifting equipment and machine tools of all makes.

SMARTER HOW?

Konecranes shipbuilding equipment and services are SMARTER WHERE IT MATTERS. We back up this claim with our long history in the lifting business coupled with an extensive knowledge of modern crane technology and the shipbuilding industry. We have the skills and resources to provide excellent products and localized service that ensures your cranes will be a sound, safe investment. Our customers know us as a partner with a clear vision that helps them succeed.

Our shipyard equipment helps you build your ships faster, from handling steel plates, to assembling the hull, and on to the final outfitting. Our technology contributes to a safe working environment, reduces air and noise pollution, and allows your shipyard to operate more efficiently. We are successful because we deliver all of the above, with the lowest possible cost of ownership.

Smarter where? On your bottom line.

www.konecranes.com