

TECHNICAL DESCRIPTION

Konecranes Battery RTG (B-RTG)

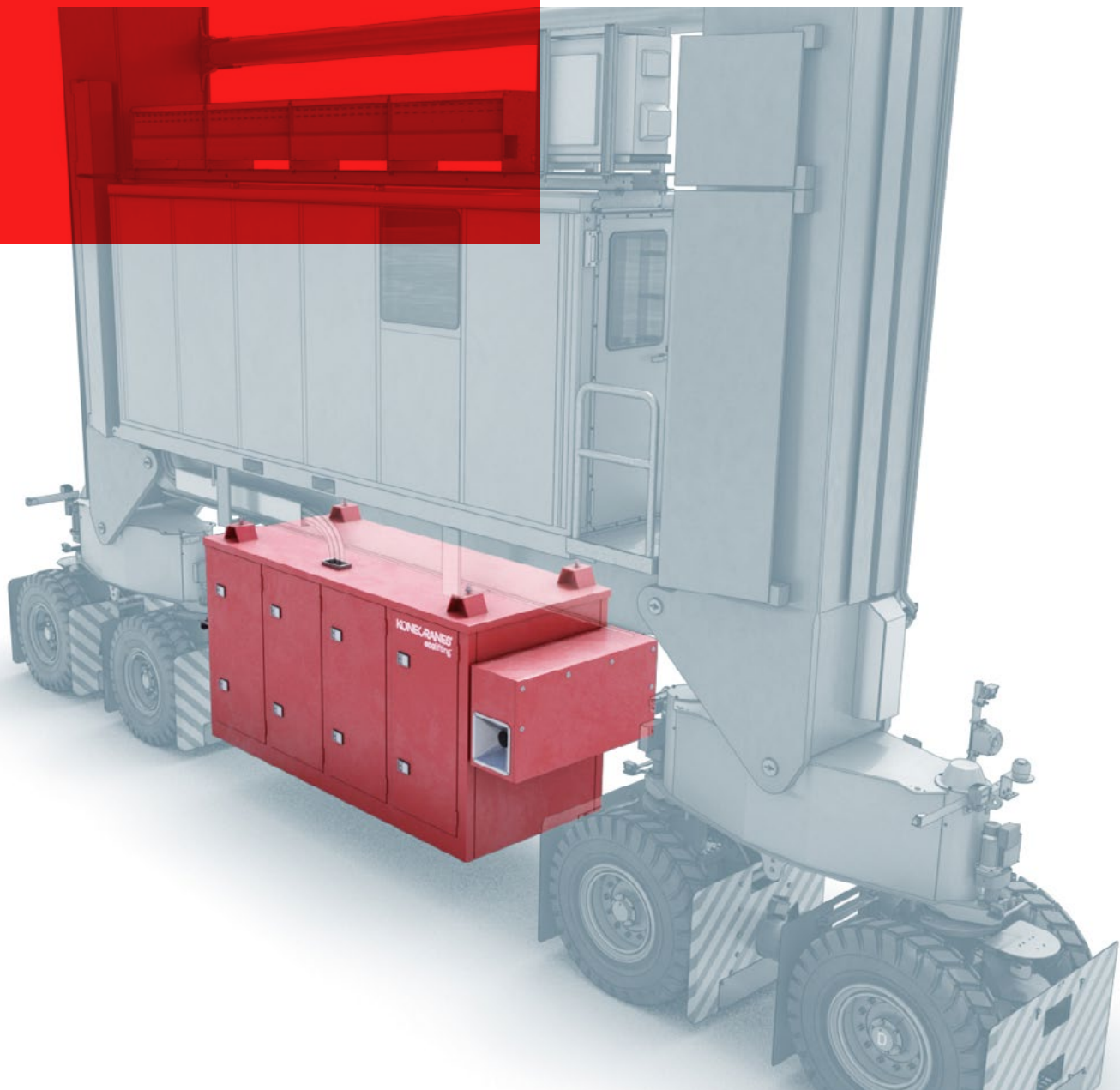

New power option! Battery

Konecranes is proud to be the first to introduce a battery power option for RTGs. If you're interested in all-electric RTG operation, our new battery option deserves your serious consideration. It gives the freedom of diesel-powered operation without the CO₂ and noise emissions. It gives the eco-efficiency of all-electric operation while "cutting the strings" of cable reel and busbar infrastructure in the yard.

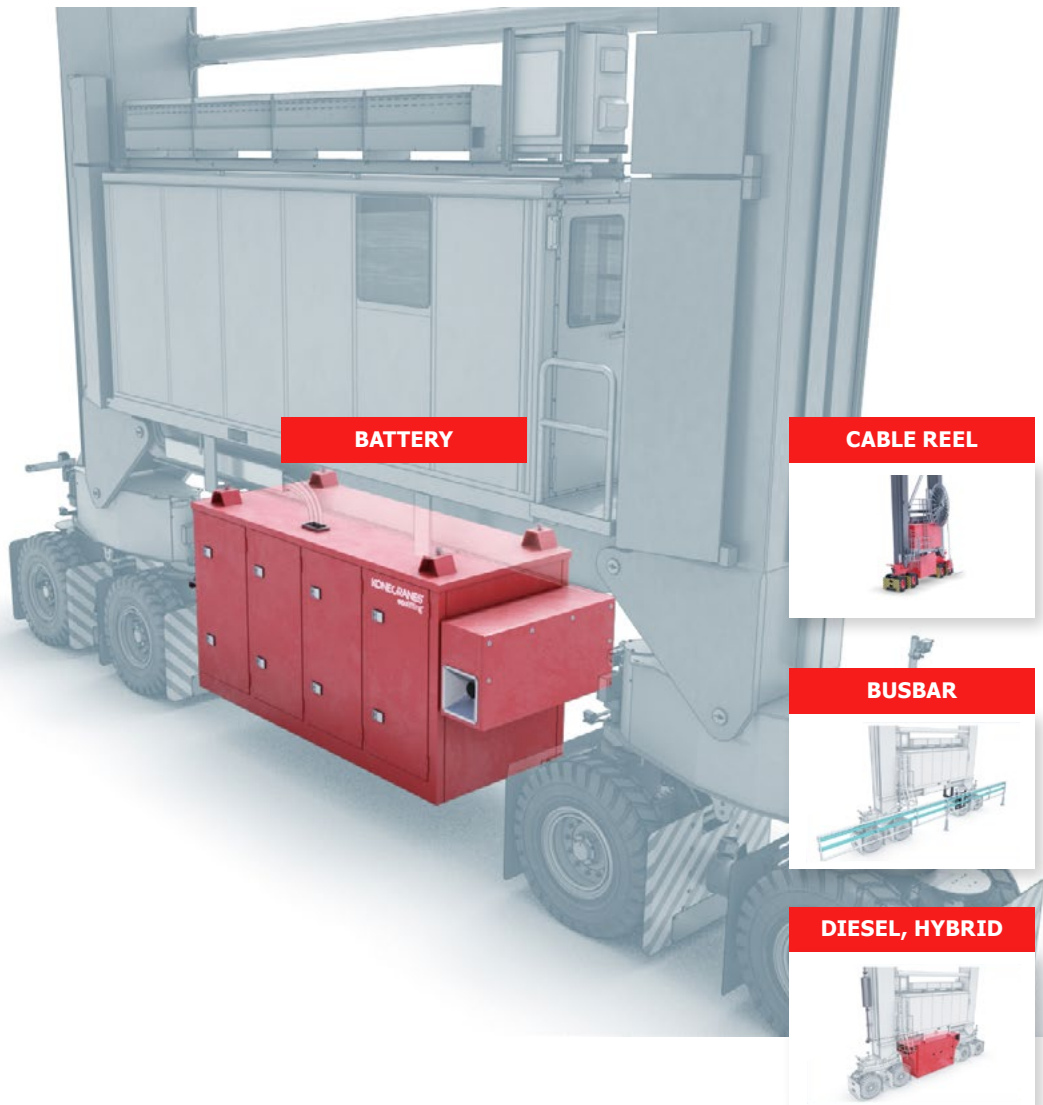

Battery-driven RTG with uncompromised performance

In 1995, Konecranes introduced its first RTG to market. It was hydraulics-free and featured the Active Load Control (ALC) system which eliminated container sway. This RTG was enthusiastically accepted. Since then, Konecranes has systematically improved its RTG, particularly in the area of power consumption and energy management. There is a growing market demand for energy-efficient, low-emission RTGs and battery technology has improved immensely with Li-ion.

Ecolifting is Konecranes' long-term vision to reduce the CO₂ and noise emissions of its container handling equipment. Moving along from the first diesel-driven Konecranes RTG, we offered fully-electric RTGs with a choice of cable reel or busbar systems. Then we offered a hybrid RTG, which has become popular. We learned a lot about battery management and behavior from our hybrid RTG, equipped with a battery pack. Seeing the global "battery megatrend" gathering strength in a worldwide effort to reduce CO₂ emissions, Konecranes is now the first to offer a battery-driven RTG as part of Ecolifting. In some countries, state subsidies can be won for purchasing hybrid or battery RTGs: the political climate is favoring port decarbonization.



- Available today
- Feasible to develop

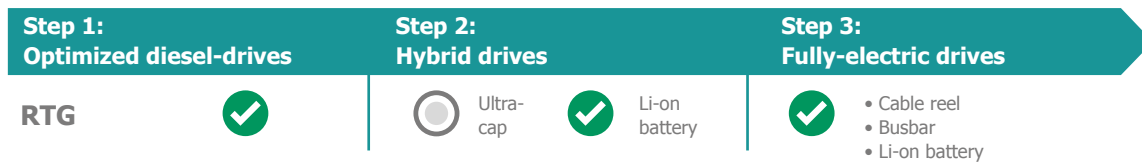

Cutting the strings

Fully-electric RTGs powered via busbar or cable reel systems require yard infrastructure adjustments that are not feasible for all container terminal operators. The Konecranes B-RTG can be adopted easily by brownfield container terminals without major yard adjustments. The technology can also be retrofitted to any brand of RTG. With the Konecranes B-RTG, you go to zero local carbon emissions and "cut the strings" of yard infrastructure requirements.

Note about retrofitting

Konecranes B-RTG technology can be retrofitted to non-Konecranes RTG brands if the following preconditions are met:

- The position of the diesel genset is underneath the sill-beam
- The available space between the bogie wheel arrangement is big enough to accommodate the battery e-room including space needed for charging
- The existing drive and control system of the RTG is inverter-controlled with a common DC-bus link, the preferred PLC being Siemens S7

Konecranes B-RTG: charging to freedom

The Konecranes B-RTG works either with a charging station (seen at right) or with manual plug-in to the mains for charging. This will depend on the particular work processes of your container terminal.

If a charging station is used, it can be placed in various ground-level container slots for convenient B-RTG access. Regular containers can be stacked on top of it. It is connected to the harbor mains via regular underground cables.

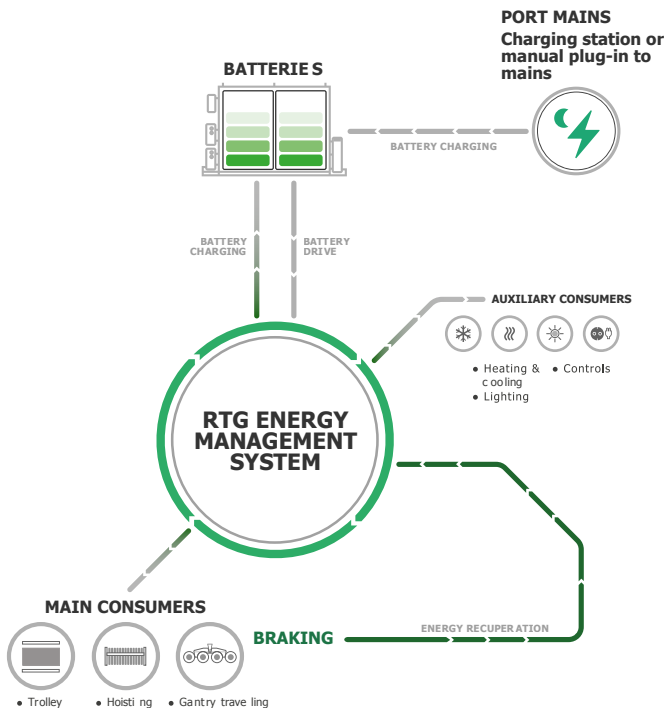

The Konecranes B-RTG utilizes Li-ion technology that is field-proven in Konecranes Gottwald Automated Guided Vehicle (AGV) systems, as well as in hybrid Konecranes RTGs. The performance track record is excellent. At left you see an illustration of the energy management system.

Konecranes B-RTG: e-room and charging

The Li-ion batteries are housed in the battery room, seen at right. The battery room is equipped with air conditioning for heating or cooling as outside temperature dictates, keeping an optimum temperature inside the battery room for optimum battery performance.

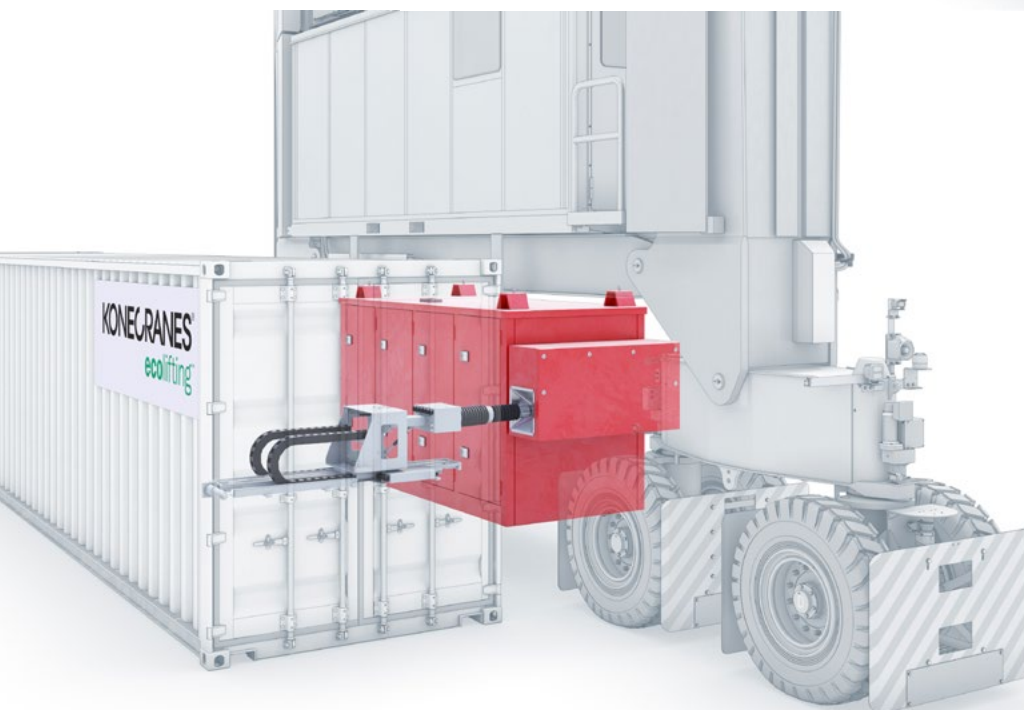
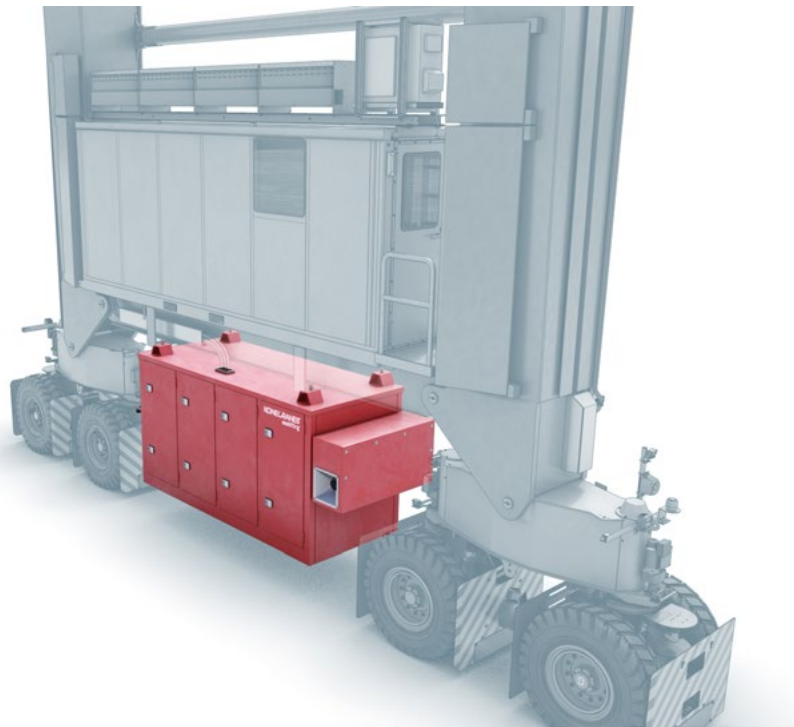

Docking at the charging station is a simple matter of gantrying the B-RTG to the station, where the charging connection is made. This can be done in automated mode, in ARTG operation, or in manual operation. Regular containers can be stacked on top of the charging station, which is just another container as far as stack operations are concerned. Charging can also be done via manual connection to the port mains. This is an easy-entry solution for e.g. intermodal terminals.

Konecranes B-RTG

Technical information

Battery type	Battery packs available in two types. First type is liquid-cooled with 4-hr = 222kWh capacity, second type is liquid-cooled with 8-hr = 296kWh capacity.
Battery life	The design life of the battery pack is 8 years. The limit of design life is specified as 70% of the remaining battery capacity. Battery life is dependent upon the B-RTG work load in relation to work shift. More detailed information can be given in discussion with the customer about work processes involving charging and discharging* cycles.
Battery pack modularity	The battery packs are entirely modular for easy access, maintenance and replacement.
Running time	Depends on the work cycles of the container terminal in question. More detailed information is given in discussion with the customer about work processes and work cycle requirements.
Charging time	The battery packs are charged in 1 hr at the full rated charging power with a charging rate of 1C.
System redundancy	The battery modules are divided into two sub-modules. Each sub-module provides 50% of the power and capacity. If one sub-module fails, the other one remains functional.

* The number of cycles describes the sum of all full charge cycles over the battery lifetime. One full charge cycle is reached when the usable capacity under consideration of the State of Health (SOH) is discharged and charged. This process can be divided into subcycles.



Konecranes is a world-leading group of Lifting Businesses™, serving a broad range of customers, including manufacturing and process industries, shipyards, ports and terminals. Konecranes provides productivity enhancing lifting solutions as well as services for lifting equipment of all makes. In 2021, Group sales totaled EUR 3.2 billion. The Group has around 16,600 employees in 50 countries. Konecranes shares are listed on the Nasdaq Helsinki (symbol: KCR).

© 2022 Konecranes. All rights reserved. 'Konecranes', 'Lifting Businesses' and  are either registered trademarks or trademarks of Konecranes.

This publication is for general informational purposes only. Konecranes reserves the right at any time, without notice, to alter or discontinue the products and/or specifications referenced herein. This publication creates no warranty on the part of Konecranes, express or implied, including but not limited to any implied warranty or merchantability or fitness for a particular purpose.